

# HÄFELE

DE Geschirrspüler / Gebrauchsanweisung







CAPELLA 533.29.501

**Vielen Dank, dass Sie sich für dieses Produkt entschieden haben.**

In dieser Gebrauchsanweisung finden Sie wichtige Sicherheitshinweise sowie Informationen zur Bedienung und Wartung Ihres Geräts.

Lesen Sie diese Gebrauchsanweisung vor der ersten Benutzung des Geräts aufmerksam durch und bewahren Sie sie sorgfältig auf.

Symbol	Typ	Bedeutung
	<b>WARNUNG</b>	Lebensgefahr/Gefahr schwerer Verletzungen
	<b>STROMSCHLAGGEFAHR</b>	Gefährliche elektrische Spannung
	<b>BRANDGEFAHR</b>	Warnung: Brandgefahr / Entflammbare Materialien
	<b>ACHTUNG</b>	Gefahr von Personen- und Sachschäden
	<b>WICHTIG HINWEIS</b>	Informationen für den ordnungsgemäßen Betrieb des Geräts

# INHALT

<b>1.SICHERHEITSHINWEISE.....</b>	<b>1</b>
1.1 Allgemeine Sicherheitshinweise .....	1
1.2 Hinweise zur Aufstellung .....	2
1.3 Hinweise zum Betrieb .....	3
<b>2.AUFSTELLEN UND ANSCHLIESSEN.....</b>	<b>5</b>
2.1 Positionierung des Geräts .....	5
2.2 Wasseranschluss .....	5
2.3 Zulaufschlauch .....	5
2.4 Elektrischer Anschluss .....	6
<b>3.TECHNISCHE DATEN .....</b>	<b>7</b>
3.1 Gerät im Überblick.....	7
3.2 Technische Daten .....	7
<b>4.GERÄT BETRIEBSBEREIT MACHEN.....</b>	<b>9</b>
4.1 Vor der ersten Verwendung .....	9
4.2 Salz einfüllen .....	9
4.3 Teststreifen .....	10
4.4 Wasserhärte-tabelle.....	10
4.5 Wasserenthärtungssystem .....	10
4.6 Einstellungen .....	10
4.7 Reiniger verwenden.....	11
4.8 Reiniger einfüllen.....	11
4.9 Kombi-Reiniger verwenden .....	11
4.10 Klarspülmittel verwenden .....	11
4.11 Klarspülmittel einfüllen und einstellen.....	11
<b>5.GESCHIRRSP LER BELADEN.....</b>	<b>13</b>
5.1 Empfehlungen .....	13
5.2 Alternative Korb-beladungen .....	15
<b>6.PROGRAMM BERSICHT.....</b>	<b>16</b>
<b>7.BEDIENFELD.....</b>	<b>18</b>
7.1 Programm wechseln.....	18
7.2 Programm abrechnen.....	19
7.3 Gerät ausschalten .....	19

# INHALT

<b>8.REINIGUNG UND WARTUNG.....</b>	<b>21</b>
8.1 Gerät und Filter reinigen.....	21
8.2 Sprüharme .....	21
<b>9.FEHLERBEHEBUNG.....</b>	<b>23</b>

# 1. SICHERHEITSHINWEISE

## 1.1 Allgemeine Sicherheitshinweise

- Lesen Sie diese Gebrauchsanweisung vor der ersten Benutzung des Geräts aufmerksam durch, und bewahren Sie sie sorgfältig auf.

 Prüfen Sie Gerät und Verpackung auf eventuelle Beschädigungen. Sind Schäden erkennbar, das Gerät nicht einschalten! Kundendienst kontaktieren!

- Das Gerät auspacken wie angegeben. Die Verpackung vorschriftsgemäß entsorgen.

 Dieses Gerät kann von Kindern ab einem Alter von 8 Jahren oder von Personen mit eingeschränkten physischen, sensorischen oder mentalen Fähigkeiten oder mangelnder Erfahrung verwendet werden, wenn sie dabei beaufsichtigt werden oder in der sicheren Bedienung des Geräts angemessen unterwiesen wurden und die damit verbundenen Gefahren verstehen. Kinder nicht mit dem Gerät spielen lassen!

 Die Verpackung vom Gerät entfernen! Von Kindern fern halten!

 Kinder nicht mit dem Gerät spielen lassen!

 Spül- und Klarspülmittel außerhalb der Reichweite von Kindern halten!

 Nach dem Reinigungsprogramm können im Gerät Rückstände zurückbleiben. Kinder von geöffnetem Gerät fernhalten!

 Sicherstellen, dass Altgeräte nicht zur Falle für Kinder werden! Kinder schließen sich selbst im Innenraum alter Geräte ein! Um dies zu verhindern: Schloss unwirksam machen und Netzkabel abschneiden!

## 1.2 Hinweise zur Aufstellung

- Geeigneten und sicheren Aufstellungsort auswählen!
- Befolgen Sie die Anweisungen zur Aufstellung und zum Anschließen des Geräts!
- Bei Reparaturen ausschließlich Original-Ersatzteile verwenden!

 Das Gerät vor dem Aufstellen von der Stromversorgung trennen!

 Aufstellung ausschließlich durch autorisierte Kundendiensttechniker!

 Sicherstellen, dass in Ihrer elektrischen Hausinstallation die gesetzlich vorgeschriebenen Sicherungen installiert sind!

 Alle elektrischen Anschlüsse müssen mit den Daten auf dem Typenschild übereinstimmen.

 Das Gerät nicht auf das Netzkabel stellen!

 Direkt an Steckdose anschließen! Keine Verlängerungskabel/Verteilerdosen zwischenschalten!

 Die Steckdose muss auch nach der Aufstellung des Geräts zugänglich sein.

- Nach der Aufstellung, das Gerät einmal ohne Beladung laufen lassen.

 Das Gerät von der Stromversorgung trennen, bevor Sie mit dem Aufstellen beginnen!

 Das Gerät ausschließlich mit dem mitgelieferten Schutzstecker anschließen.

 Wenn das Netzkabel beschädigt ist, durch einen Elektriker austauschen lassen! Lebensgefahr!

## 1.3 Hinweise zum Betrieb

- Dieses Gerät ist für den Gebrauch in Privathaushalten ausgelegt. Nicht für andere Zwecke einsetzen! Bei gewerblicher Nutzung erlöschen alle Garantieansprüche.

⚠ Nicht auf die geöffnete Tür stellen oder setzen. Keine Lasten auf die Tür stellen.

⚠ Ausschließlich Spülmittel und Klarspülmittel verwenden, die für Spülmaschinen hergestellt wurden. Der Hersteller übernimmt keinerlei Haftung für nicht bestimmungsgemäßen oder missbräuchlichen Gebrauch.

⚠ Wasser aus dem Gerät nicht trinken!

⚠ Keine chemischen Lösungsmittel in das Gerät einbringen! Explosionsgefahr!

- Kunststoffteile auf Hitzebeständigkeit testen, bevor Sie diese in den Geschirrspüler stellen.

⚠ Kinder dürfen das Gerät nicht ohne Aufsicht reinigen oder warten.

⚠ Keine Fremdkörper in das Gerät stellen! Körbe nicht überladen!

- Der Hersteller übernimmt keine Haftung für Verformungen im Innenraum des Geräts infolge missbräuchlicher Verwendung.

⚠ Auf das Programmende warten, bevor Sie die Tür öffnen! Gefahr durch herausspritzendes heißes Wasser! Sicherheitsvorrichtungen sorgen für einen Programmstopp beim Öffnen der Tür.

⚠ Die Tür des Geräts nicht geöffnet lassen! Unfallgefahr!

⚠ Messer und andere scharfe Objekte nach unten gerichtet in den Besteckkorb stellen!

 Bei Modellen mit automatischem Türöffnungssystem wird bei aktiviertem Energiesparmodus am Programmende die Tür geöffnet. Um Schäden am Geschirrspüler zu vermeiden, innerhalb der ersten Minute nach dem automatischen Öffnen die Tür nicht zudrücken! Für eine effektive Trocknung, die Tür nach dem Programmende 30 Minuten geöffnet lassen! Wenn der Signalton für die automatische Türöffnung wiedergegeben wird, von der Tür fernhalten!

 Reparaturen dürfen nur durch qualifizierte Kundendiensttechniker ausgeführt werden! Bei Nichtbeachtung erlöschen alle Garantieansprüche.

 Das Gerät vom Stromnetz trennen, bevor mit den Reparaturarbeiten begonnen wird. Immer am Stecker ziehen, nicht am Netzkabel! Den Hahn für Zulaufwasser schließen.

 Bei Betrieb mit niedriger Spannung wird die Leistung des Geräts beeinträchtigt.

 Nach dem Programmende aus Sicherheitsgründen den Netzstecker ziehen.

 Den Netzstecker nicht mit feuchten Händen berühren! Gefahr eines elektrischen Schlages!

 Immer am Stecker ziehen, nicht am Netzkabel!



## 2. AUFSTELLEN UND ANSCHLIESSEN

### 2.1 Positionierung des Geräts

Das Gerät an einem Ort aufstellen, der leichtes Beladen und Entladen ermöglicht. Das Gerät nicht an Orten aufstellen, an denen die Umgebungstemperatur unter 0 °C fallen kann.

Lesen und beachten Sie alle Warnungen auf der Verpackung, bevor Sie die Verpackung entfernen und das Gerät aufstellen!

Das Gerät in der Nähe von Wasserhahn und Abfluss aufstellen. Beachten Sie, dass sich die Anschlüsse nach dem Aufstellen des Geräts nicht mehr ohne Weiteres korrigieren lassen.

Das Gerät nicht an Tür oder Bedienblende anheben/verschieben!

Um das Gerät herum genug Platz für ausreichende Bewegungsfreiheit lassen!

 Sicherstellen, dass Zulauf- und Ablaufschlauch nicht gequetscht werden und nicht hängen bleiben. Das Gerät nicht auf das Netzkabel stellen! Auch nicht kurzzeitig!

Die Füße so einstellen, dass das Gerät gerade steht. Das Gerät auf einer glatten Fläche aufstellen. Bei Nichtbeachtung wird das Gerät nicht stabil stehen und die Tür wird sich nicht richtig schließen lassen.

### 2.2 Wasseranschluss

Wir empfehlen den Einbau eines Filters für das Zulaufwasser, um Schäden am Gerät durch Verunreinigungen auszuschließen (zum Beispiel durch Sand, Rost aus dem Leitungssystem). Mit einem Filter lassen sich auch Verfärbungen und Ablagerungen im Innenraum vermeiden.

Beachten Sie den Aufdruck auf dem Wasserzulaufschlauch!

Mit 25 ° gekennzeichnete Modelle dürfen nur mit maximal 25 °C warmem (kaltem) Wasser gespeist werden.

Für alle übrigen Modelle:

Kaltes Wasser bevorzugt; warmes Wasser max.

Temperatur 60 °C.

### 2.3 Zulaufschlauch





 **WARNUNG:** Mitgelieferten Zulaufschlauch verwenden. Eventuell vorhandenen Zulaufschlauch eines Altgeräts NICHT verwenden.

 **WARNUNG:** Neuen Schlauch vor dem Anschließen mit Wasser spülen.

 **WARNUNG:** Schlauch direkt an den Wasserhahn anschließen. Der Wasserdruck muss zwischen 0,03 MPa und 1 MPa liegen. Übersteigt der Wasserdruck in der Zuleitung 1 MPa, Überdruckventil zwischen Wasserhahn und Schlauch installieren.

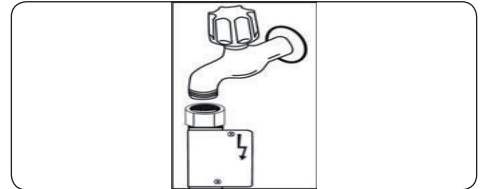
 **WARNUNG:** Nach dem Anschließen Wasserhahn ganz aufdrehen und System auf Leckagen prüfen. Nach jedem Spülprogramm Wasserhahn schließen.



 **WARNUNG:** Einige Modelle werden mit Aquastop-System geliefert. Dieses nicht beschädigen und nicht knicken oder verdrehen.

## 2.4 Ablaufschlauch

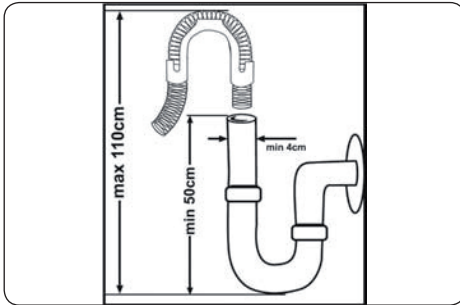

Ablaufschlauch direkt an den Abfluss anschließen. Anschlussstelle muss sich in einer Höhe zwischen 50 cm und 110 cm über dem Boden befinden.



**WICHTIG:** Bei einer Ablaufschlauchlänge über 4 m ist keine hinreichende Reinigungsleistung mehr

## 2.5 Elektrischer Anschluss

**! WARNUNG:** Das Gerät ist für 220–240 V ausgelegt. Wenn Ihre Elektroinstallation mit 110 V arbeitet, schalten Sie einen Transformator 110/220 V (3000 W) zwischen.



**Schutzkontaktstecker des Geräts mit einer passenden Steckdose mit geeigneter Spannung und Stromstärke verbinden.**



**Ist keine Erdung vorhanden, diese von einem Elektriker nachrüsten lassen. Der Hersteller übernimmt keinerlei Haftung für Schäden infolge fehlender Erdung.**



**Der Stecker dieses Geräts kann eine 13 A-Sicherung enthalten (zum Beispiel in Großbritannien oder Saudi-Arabien)**

### 3. TECHNISCHE DATEN

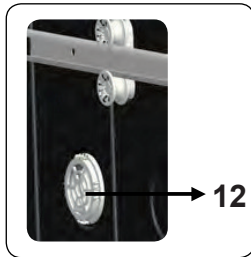
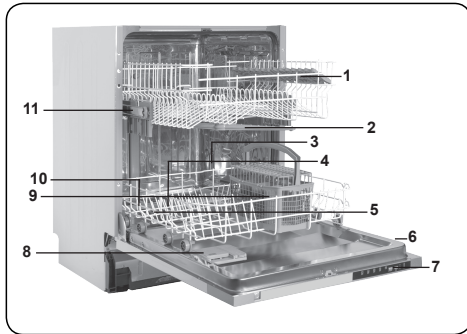

#### 3.1 Gerät im Überblick

1. Oberer Korb mit Geschirrhaltern
2. Oberer Sprüharm
3. Unterer Korb
4. Unterer Sprüharm
5. Filter
6. Typenschild
7. Bedienblende
8. Fächer für Spülmittel und Klarspüler
9. Besteckkorb
10. Salzbehälter
11. Schienenstopper oberer Korb
12. Aktives Trocknungssystem: Mit diesem System wird das Trocknen Ihres Geschirrs beschleunigt.

#### 3.2 Technische Daten

Kapazität	12 Maßgedecke
Abmessungen (mm)	
Höhe	820-870 (mm)
Breite	598(mm)
Tiefe	570 (mm)
Gewicht (netto)	31,400 kg
Betriebsspannung / Netzfrequenz	220–240 V / 50 Hz
Stromaufnahme (A)	10 (A)
Leistungsaufnahme (W)	1900 (W)
Zulaufwasserdruck	Maximal:1 (MPa), Minimal:0,03 (MPa)

## RECYCLING

- Einige Gerätekomponenten und Verpackungselemente sind wiederverwertbar.
- Kunststoffe sind mit den international vereinheitlichten Symbolen gekennzeichnet: (>PE<, >PP< usw.)
- Die Pappteile der Verpackung bestehen aus recycelter Pappe. Sie können für erneutes Recycling in Papiercontainern entsorgt werden.
- Einige Materialien dürfen nicht über den Hausmüll entsorgt werden. Abgabe an kommunalen Abfallsammelpunkten!
- Informationen zur Entsorgung unterschiedlicher Materialien erhalten Sie bei Ihrem kommunalen Abfallsammelpunkt.

## VERPACKUNG UND UMWELTSCHUTZ

- Die Verpackung schützt das Gerät während des Transports. Die Verpackungsmaterialien sind umweltfreundlich, da sie wiederverwertbar sind. Der Einsatz wiederverwertbarer Materialien reduziert das Müllaufkommen und schont die natürlichen Ressourcen.

### CE-Konformitätserklärung

Wir erklären hiermit, dass unsere Produkte die einschlägigen europäischen Richtlinien, Entscheidungen und Vorschriften sowie die Anforderungen der genannten Normen erfüllen.

### Entsorgung Ihres Altgeräts



Das Symbol auf dem Produkt oder seiner Verpackung zeigt an, dass das Produkt nicht mit dem normalen Hausmüll entsorgt werden darf. Übergeben Sie es Ihrer kommunalen Sammelstelle für Elektroabfälle.

Indem Sie sicherstellen, dass dieses Gerät ordnungsgemäß entsorgt wird, helfen Sie bei der Vermeidung möglicher negativer Auswirkungen auf die Umwelt und die menschliche Gesundheit, die durch eine nicht vorschriftsmäßige Entsorgung entstehen können. Weitere Informationen zum Recycling dieses Produkts erhalten Sie bei Ihren kommunalen Behörden, bei Ihrem Entsorgungsunternehmen und bei dem Händler, bei dem Sie das Produkt gekauft haben.

## 4. VOR VERWENDUNG DES GERÄTES

### 4.1. Vorbereitung Ihres Geschirrspülers auf die erste Inbetriebnahme

- Stellen Sie sicher, dass Ihre Strom- und Wasserversorgung den Werten entspricht, die vom Hersteller des Gerätes in den Installationsanweisungen gefordert werden.
- Das gesamte Verpackungsmaterial aus dem Geräteinneren entfernen.
- Den Wasserenthärterstand einstellen.
- Den Klarspülbehälter auffüllen.

### 4.2 Salzverwendung (falls zutreffend)

Für eine gute Spüleistung benötigt dieser Geschirrspüler weiches, d. h. entkalktes Wasser. Andernfalls kommt es zu Kalkablagerungen am Geschirr und im Innenraum des Gerätes. Dadurch wird die Leistung des Gerätes beim Spülen, Trocknen und Klarspülen negativ beeinträchtigt. Wenn Wasser durch das Wasserenthärterssystem fließt, werden die für die Wasserhärte verantwortlichen Ionen aus dem Wasser entfernt und das Wasser erreicht die Qualität, die für eine optimale Spüleistung erforderlich ist. Je nach Wasserhärtegrad des zulaufenden Wassers sammeln sich die für die Wasserhärte verantwortlichen Ionen schnell im Wasserenthärterssystem. Aus diesem Grund muss das Wasserenthärterssystem so aufgefrischt werden, dass es auch beim nächsten Spülgang wieder mit der gleichen optimalen Leistung arbeitet. Aus diesem Grund ist das Spezi­alsalz erforderlich.

Die Maschine darf nur mit speziellem Geschirrspülsalz zur Wasserenthärtung verwendet werden. Verwenden Sie keine feinkörnigen oder pulverförmigen Salze, die leicht löslich sind. Die Verwendung jeder anderen Art von Salz kann Ihre Maschine beschädigen.

### 4.3. Salz auffüllen

Zum Einfüllen des Enthärtungssalzes drehen Sie die Kappe des Salzbehälters gegen den Uhrzeigersinn auf. **(1) (2)** Das

Fach bei der ersten Inbetriebnahme mit 1 kg Salz und Wasser **(3)** randvoll füllen. Ein Trichter **(4)** vereinfacht das Einfüllen. Kappe wieder anbringen und schließen. Alle 20 bis 30 Durchläufe Salz in die Maschine nachfüllen (ca. 1 kg).

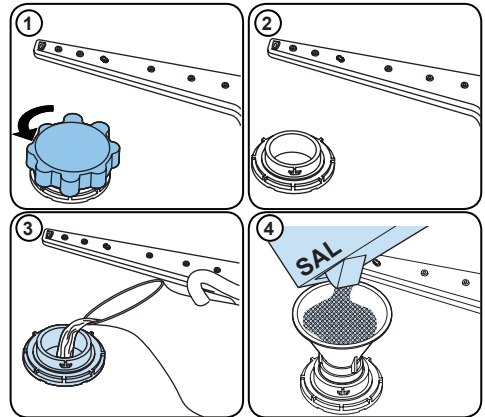







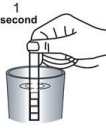
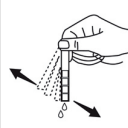

### Nur bei der ersten Inbetriebnahme Salz in den Salzbehälter geben.

Verwenden Sie ausschließlich spezielles Enthärtungssalz für den Gebrauch in Geschirrspülern.

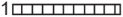
Wenn Sie Ihren Geschirrspüler starten, füllt sich der Salzbehälter mit Wasser. Füllen Sie das Enthärtungssalz daher vor dem Start Ihrer Maschine ein.

Falls das Enthärtungssalz überläuft und Sie die Maschine nicht sofort starten, schützen Sie Ihre Maschine vor Korrosion, indem Sie ein kurzes Spülprogramm ausführen.

#### 4.4. Teststreifen

Wasserhahn öffnen, Wasser laufen lassen (1 Min).	Streifen in das Wasser halten (1 s).	Streifen schütteln.	Warten (1 Min).	Härtegrad Ihrer Maschine auf den ermittelten Wert einstellen.
				1  2  3  4  5  6 

**HINWEIS:** Der Härtegrad ist standardmäßig auf 3 eingestellt. Falls Sie Brunnenwasser nutzen oder der Härtegrad 90 dF übersteigt, sollten Sie eine Filter- oder Aufbereitungsanlage verwenden.

#### 4.5. Wasserhärte-tabelle

Stufe	Deutsche Härte (dH)	Französische Härte (dF)	Britische Härte (dE)	Anzeige
1	0 - 5	0 - 9	0 – 6	L1 wird am Display angezeigt.
2	6 - 11	10 - 20	7 – 14	L2 wird am Display angezeigt.
3	12 - 17	21 - 30	15 – 21	L3 wird am Display angezeigt.
4	18 - 22	31 - 40	22 – 28	L4 wird am Display angezeigt.
5	23 - 34	41 - 60	29 - 42	L5 wird am Display angezeigt.
6	35 - 50	61 - 90	43 - 63	L6 wird am Display angezeigt.

#### 4.6. Wasserenthärtungssystem

Der Geschirrspüler ist mit einem Wasserenthärter ausgestattet, der die Härte des Leitungswassers verringert. Den Härtegrad Ihres Leitungswassers erfahren Sie bei Ihrem Versorgungsunternehmen oder mit Hilfe eines Teststreifen (falls verfügbar).

#### 4.7. Einstellung

- Öffnen Sie die Gerätetür.
- Schalten Sie das Gerät ein und drücken Sie die Programmtaste, sobald es eingeschaltet ist.
- Halten Sie die Programmtaste gedrückt, bis „SL“ verschwindet.
- Die Maschine zeigt die letzte Einstellung an.
- Stellen Sie die gewünschte Stufe mit der Programmtaste ein.
- Schalten Sie zum Speichern der Einstellung die Maschine aus.

#### 4.8. Gebrauch von Spülmitteln

Verwenden Sie nur spezielle Spülmittel für Haushalts-Geschirrspüler. Bewahren Sie Spülmittel an einem kühlen, trockenen Ort außerhalb der Reichweite von Kindern auf. Geben Sie für optimale Leistung genau die empfohlene Menge Spülmittel für das

ausgewählte Programm hinzu. Die benötigte Spülmittelmenge hängt vom Zyklus, der Lademenge und dem Verschmutzungsgrad des Geschirrs ab.

Füllen Sie nicht mehr Spülmittel als erforderlich in das Spülmittelfach ein, da dies sonst weißliche Streifen oder bläuliche Schlieren auf Glas und Geschirr sowie Glaskorrosion verursachen könnte. Eine fortgesetzte Verwendung von zu viel Spülmittel kann zu Maschinenschäden führen.

Die Verwendung von zu wenig Spülmittel kann zu einer schlechten Reinigung und bei hartem Wasser zu weißlichen Schlieren führen.

Weitere Informationen entnehmen Sie bitte den Anweisungen des Spülmittelherstellers.

#### 4.9. Spülmittel einfüllen

Verschieben Sie die Verriegelung zum Öffnen des Behälters und füllen Sie das Spülmittel ein.

Schließen Sie den Deckel und drücken Sie ihn fest, sodass er einrastet. Der Behälter sollte unmittelbar vor Beginn jedes Programmes aufgefüllt werden. Falls das Geschirr stark verschmutzt ist, geben Sie zusätzliches Spülmittel in die Vorspülkammer.

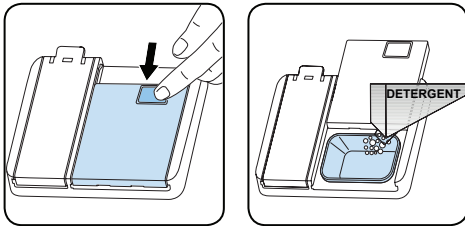

#### 4.10. Kombinierte Reiniger

Diese Produkte sollten entsprechend den Herstelleranweisungen genutzt werden.

Kombinierte Reiniger dürfen nie direkt in die Maschine oder in den Besteckkorb gefüllt werden.

Kombinierte Reiniger enthalten je nach Kombination nicht nur Spülmittel, sondern auch Klarspüler, Salzersatzstoffe und zusätzliche Komponenten.

Wir empfehlen, kombinierte Reiniger nicht in Kurzprogrammen zu verwenden. Bei solchen Programmen sollten Sie Spülmittel in Pulverform einsetzen.

Falls bei der Benutzung kombinierter Reiniger Probleme auftreten, wenden Sie

sich bitte an den Spülmittelhersteller.

Wenn Sie die Verwendung kombinierter Spülmittel einstellen, müssen Sie sicherstellen, Wasserhärte und Klarspüler auf passende Werte einzustellen.

#### 4.11. Klarspüler

Ein Klarspüler hilft, das Geschirr streifen- und fleckenfrei zu trocknen. Damit Ihre Utensilien fleckenfrei und Ihre Gläser klar werden, ist Klarspüler unumgänglich. Der Klarspüler wird während der Heißspülphase automatisch hinzugegeben. Wenn die Dosierung des Klarspülers zu niedrig eingestellt ist, bleiben weißliche Flecken auf dem Geschirr zurück, das Geschirr trocknet nicht richtig und wird nicht sauber gespült.

Wenn Sie zu viel Klarspüler dosieren, entstehen bläuliche Schichten auf Glas und Geschirr.

#### 4.12. Klarspüler einfüllen und einstellen

Öffnen Sie die Kappe des Klarspülerbehälters, um ihn zu befüllen. Füllen Sie den Behälter bis zur MAX-Markierung mit Klarspüler und schließen Sie die Kappe. Achten Sie darauf, den Behälter nicht übermäßig zu füllen. Wischen Sie verschütteten Klarspüler auf.

#### Ändern Sie die Klarspülerstufe wie folgt, bevor Sie die Maschine einschalten:

- Öffnen Sie die Gerätetür.
- Schalten Sie das Gerät ein und drücken Sie die Programmtaste, sobald es eingeschaltet ist.
- Halten Sie die Programmtaste gedrückt, bis „rA“ verschwindet. Die Klarspülereinstellung richtet sich nach der Wasserhärteinstellung.
- Die Maschine zeigt die letzte Einstellung an.
- Stellen Sie die gewünschte Stufe mit der Programmtaste ein.
- Schalten Sie zum Speichern der Einstellung die Maschine aus.

Die Werkseinstellung ist „4“.

Erhöhen Sie die Stufe, falls das Geschirr nicht richtig getrocknet wird oder fleckig ist. Verringern Sie die Stufe, falls sich blaue Flecken am Geschirr bilden.

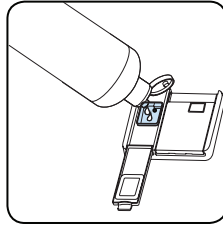
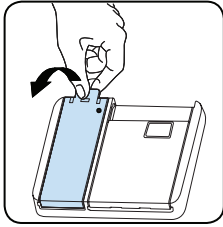

Stufe	Klarspülerdosis	Anzeige
1	Kein Klarspüler wurde ausgegeben	r1 wird am Display angezeigt.
2	1 Dosis wird ausgegeben	r2 wird am Display angezeigt.
3	2 Dosen werden ausgegeben	r3 wird am Display angezeigt.
4	3 Dosen werden ausgegeben	r4 wird am Display angezeigt.
5	4 Dosen werden ausgegeben	r5 wird am Display angezeigt.



## 5. GESCHIRRSPÜLER BELADEN

Für beste Ergebnisse befolgen Sie diese Laderichtlinien.

Die Beladung Ihres Haushaltsgeschirrspülers bis zu der vom Hersteller angegebenen Kapazität trägt zur Energie- und Wassereinsparung bei.

Das manuelle Vorspülen von Geschirrtteilen führt zu erhöhtem Wasser- und Energieverbrauch und wird nicht empfohlen. Sie können Tassen, Gläser, Stielgläser, kleine Teller, Schüsseln usw. in den oberen Korb stellen. Lehnen Sie langstielige Gläser nicht aneinander, da sie andernfalls instabil und beschädigt werden können.

Langstielige Gläser sollten an den Korbrand, die Ablage oder den Glasträger angelehnt werden und dürfen keine anderen Gegenstände berühren.

Stellen Sie alle Behälter wie Tassen, Gläser und Töpfe mit der Öffnung nach unten in den Geschirrspüler, da sich sonst Wasser darin sammelt.

Wenn die Maschine über einen Besteckkorb verfügt, sollten Sie das Besteckgitter verwenden, um das beste Ergebnis zu erzielen.

Stellen Sie alles große Geschirr (Töpfe, Pfannen, Deckel, Teller, Schüsseln usw.) und sehr schmutzige Gegenstände in das untere Regal.

Geschirr und Besteck sollten nicht übereinander gestellt werden.



**WARNUNG:** Achten Sie darauf, die Rotation der Sprüharme nicht zu behindern.



**WARNUNG:** Achten Sie darauf, dass nach dem Einfüllen des Geschirrs das Öffnen des Waschmittelbehälters nicht verhindert wird.

### 5.1. Empfehlungen

Entfernen Sie grobe Rückstände auf dem Geschirr, bevor Sie es in die Maschine stellen. Starten Sie die Maschine, wenn sie voll ist.



Überladen Sie die Laden nicht und stellen Sie kein Geschirr in den falschen Korb.



**WARNUNG:** Zur Vermeidung von Verletzungen sollten Besteckteile und Messer mit langem Griff und scharfen Spitzen wie Serviergabeln, Brotmesser usw. immer mit dem scharfen oder spitzen Ende nach unten oder waagrecht eingelegt werden.

## Oberer Korb

### Höhe einstellen

Die Stopper an den Schienenenden zu den Seiten drehen (wie im Bild unten gezeigt), dann den Korb herausziehen und abnehmen. Die Radpositionen ändern, dann den Korb wieder auf die Schiene setzen und die Stopper schließen. Wenn sich der obere Korb auf der erhöhten Position befindet, können große Teile wie Pfannen in den unteren Korb gestellt werden.

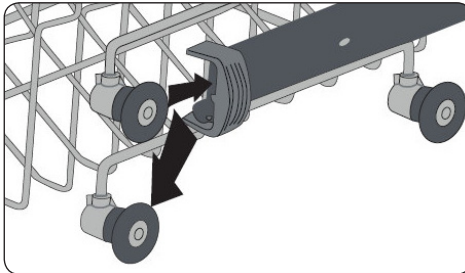

## Geschirrhalter

Die Geschirrhalter am oberen Korb können ausgeklappt (a) oder hochgeklappt (b) werden. Tassen und größere Besteckteile können Sie horizontal auf die Geschirrhalter legen.

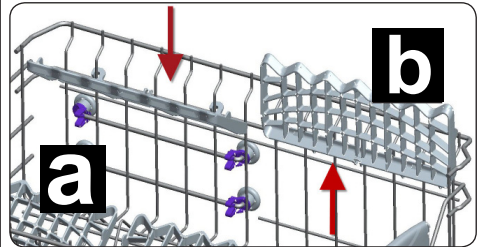

## 5.2 Alternative Korbbelastungen

### Unterer Korb

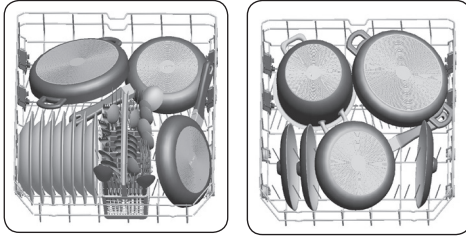

### Oberer Korb

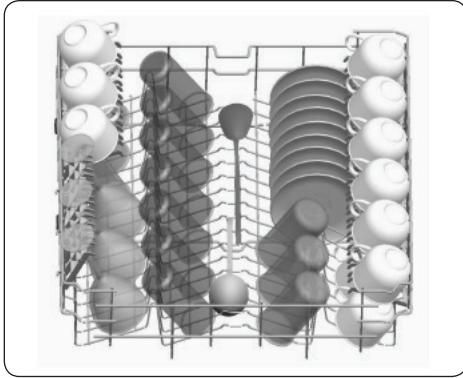

### Falsche Beladungen

Falsche Beladung kann zu schlechter Spül- und Trockenleistung führen. Bitte beachten Sie für gute Spülergebnisse die Empfehlungen des Herstellers.t

### Falsche Beladungen

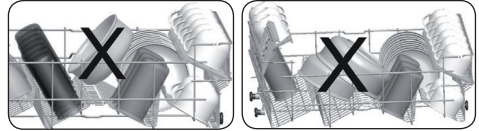
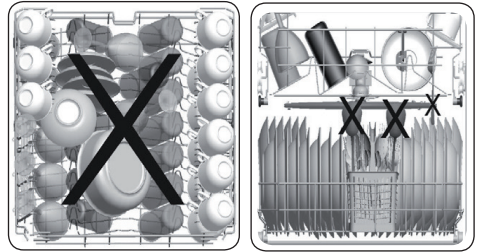

### Beispiele für Geschirrspüler ungeeignete Teile

- Zigarettenasche, Kerzenreste, Schuhcreme, Farbe, Chemikalien, Teile aus Eisenlegierungen.
- Gabeln, Löffel und Messer mit Griffen aus Holz, Knochen, Elfenbein oder mit Perlmutterbeschichtung; geklebte Teile, Teile, die mit scheuernden, sauren oder basischen Chemikalien verunreinigt sind.
- Temperaturempfindliche Kunststoffe, kupfer- oder zinnbeschichtete Behältnisse.
- Aluminium- und Silberobjekte.
- Einige empfindliche Gläser, bemaltes Porzellan, bestimmte Kristallobjekte, geklebtes Besteck, Bleikristallgläser, Schneidebretter, Kunstfaserteile.
- Absorbierende Teile wie Schwämme und Küchentücher.



**WICHTIG:** Kaufen Sie zukünftig geschirrspülergeeignete Küchengeräte.

### Hinweise für Testinstitute

Für Hinweise zu Vergleichsprüfungen gemäß EN-Normen und eine Gebrauchsanweisung in elektronischer Form senden Sie bitte Modellbezeichnung und Seriennummer an folgende Adresse: [dishwasher@standardtest.info](mailto:dishwasher@standardtest.info)

## 6. PROGRAMMTABELLE

	P1	P2	P3	P4	P5	P6	
Programmname:	Öko	Intensiv, 65 °C (je nach Modell)	Auto (je nach Modell)	Hygiene, 70 °C	Super 50 Min.	Schnell 30 Min.	Vorspülen
Art der Verschmutzung:	Standardprogramm für normal verschmutztes, täglich verwendetes Geschirr mit reduzierten Energie- und Wasserverbrauch.	Geeignet für stark verschmutztes Geschirr.	Auto-Programm für stark verschmutztes Geschirr.	Geeignet für stark verschmutztes Geschirr, das hygienisches Spülen erfordert.	Geeignet zur schnelleren Reinigung von normal verschmutztem, täglich verwendetem Geschirr.	Geeignet zur schnellen Reinigung von leicht verschmutztem Geschirr.	Geeignet zum Abspülen von Geschirr, das Sie erst später spülen möchten.
Verschmutzungsgrad:	Mittel	Stark	Stark	Stark	Mittel	Leicht	Leicht
Spülmittelmenge: A: 25 cm3 B: 15 cm3	A	A	A	A	A	A	-
Programmdauer (Std:Min)	03:25	01:57	01:25 - 01:57	02:07	00:50	00:30	00:15
Stromverbrauch (kWh/Zyklus)	0.923	1.700	1.450 - 1.700	1.900	1.100	0.740	0.020
Wasserverbrauch (l/Zyklus)	12.0	17.2	11.9 - 17.2	16.0	12.0	12.4	4.5

- Die Programmdauer kann sich je nach Geschirrmenge, Wassertemperatur, Umgebungstemperatur und ausgewählten Zusatzfunktionen ändern.
- Die für andere als das Öko-Programm angegebenen Werte sind nur Richtwerte.
- Wenn Ihr Modell mit einem Trübungssensor ausgestattet ist, hat es statt des Intensivprogramms ein Autoprogramm.
- Das Öko-Programm dient zur Reinigung von normal verschmutztem Geschirr, da es für diese Verwendung das effizienteste Programm im Hinblick auf seinen kombinierten Energie- und Wasserverbrauch ist. Darüber hinaus wird es zur Beurteilung der Einhaltung der Ökodesign-Gesetzgebung der EU verwendet.
- Das Spülen von Geschirr in einer Haushaltsgeschirrspülmaschine verbraucht in der Gebrauchsphase in der Regel weniger Energie und Wasser als das Spülen von Hand, wenn die Maschine nach den Anweisungen des Herstellers benutzt wird.
- Verwenden Sie bei Kurzprogrammen nur pulverförmiges Spülmittel.
- Kurzprogramme beinhalten keinen Trocknungsschritt.
- Zur Unterstützung der Trocknung sollten Sie die Tür nach Abschluss des Programmes leicht öffnen.
- Sie können auf die Produktdatenbank mit den Modellinformationen zugreifen, indem Sie den QR-Code auf dem Energieetikett einlesen.



**HINWEIS: (NOTE)** Gemäß den EU-Verordnungen 1016/2010 und 1059/2010 dürfen die Energieverbrauchswerte des Eco-Programms abweichen. Diese Tabelle entspricht den Verordnungen 2019/2022 und 2017/2022.

## 7. DAS BEDIENFELD

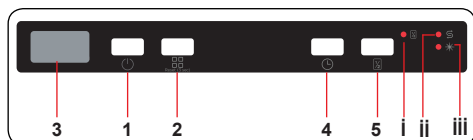

1. Ein-/Austaste
2. Programmauswahltaste
3. Display
4. Verzögerungstaste
5. Halbe Ladung-Taste
- i. Halbe Ladung-LED
- ii. Salzanzeige
- iii. Klarspüleranzeige

### 1. Ein-/Austaste

Schalten Sie die Maschine durch Drücken der

Ein-/Austaste ein. Wenn die Maschine eingeschaltet ist, wird "--" auf dem Display (3) angezeigt.

### 2. Programmauswahltaste

Wählen Sie durch Drücken der Programmauswahltaste ein passendes Programm für Ihr Geschirr aus. Das Programm startet automatisch, wenn die Tür geschlossen wird.

### 3. Display

Das Display zeigt abwechselnd die Nummer und die Gesamtzeit des gewählten Programms sowie die verbleibende Betriebszeit an.

### 4. Verzögerungstaste

Drücken Sie zum Verzögern der Startzeit eines Programmes um 1 bis 19 Stunden die Verzögerungstaste. Durch einmaliges Drücken dieser Taste wird die Startzeit um 1 Stunde verzögert; durch weiteres Drücken erhöht sich die Verzögerungszeit. Drücken Sie zum Ändern oder Abbrechen der verzögerten Startzeit die Verzögerungstaste. Wenn Sie die Maschine ausschalten, während der Verzögerungstimer aktiv ist, wird die Verzögerungszeit aufgehoben.

## 5. Halbe Ladung-Taste

Drücken Sie zum Reduzieren der Programmdauer und folglich zur Verringerung des Energie- und Wasserverbrauchs die Halbe-Beladung-Taste. Wenn die Option Halbe Ladung gewählt ist, leuchtet die Halbe Ladung-LED (i) auf.

**HINWEIS:** Wenn Sie sich entscheiden, das ausgewählte Programm nicht zu starten, beachten Sie die Abschnitte „Programm ändern“ und „Programm abbrechen“.

**HINWEIS:** Wenn sich nicht genügend Salz im Behälter befindet, zeigt die Kein-Salz-Warnleuchte (ii) an, dass der Salzbehälter leer ist.

**HINWEIS:** Wenn sich nicht genügend Klarspüler im Behälter befindet, zeigt die Kein-Klarspüler-Warnleuchte (iii) an, dass der Klarspüler-Behälter leer ist.

## 7.1 Programm ändern

Befolgen Sie die nachstehenden Schritte, wenn Sie ein Programm während des Betriebs ändern möchten.

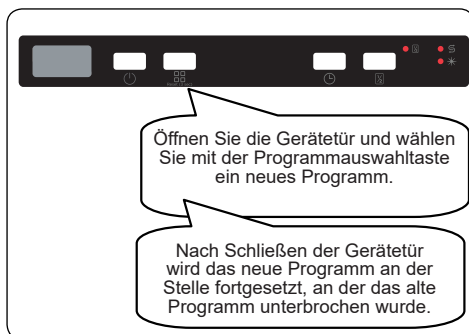

**HINWEIS:** Um ein Herausspritzen von Wasser zu vermeiden, öffnen Sie die Tür zunächst nur leicht, wenn Sie das Spülprogramm vorzeitig beenden möchten.

## 7.2 Ein Programm abbrechen

Befolgen Sie die nachstehenden Schritte, wenn Sie ein Programm während des Betriebs ändern möchten.

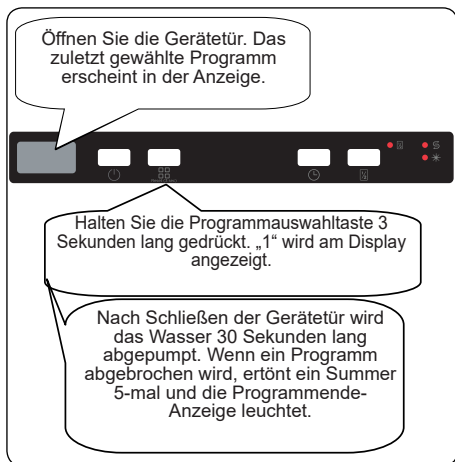

### 7.3 Maschine ausschalten

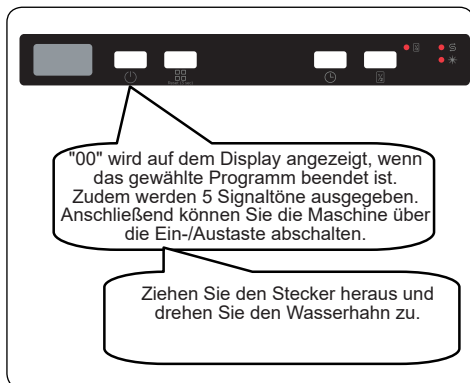

**HINWEIS:** Öffnen Sie die Tür nicht vor Abschluss eines Programmes.

**HINWEIS:** Falls die Gerätetür geöffnet wird oder ein Stromausfall eintritt, setzt die Maschine das Programm fort, sobald die Tür wieder geschlossen wird oder der Stromausfall vorüber ist.

**HINWEIS:** Falls während des Trocknens ein Stromausfall eintritt oder die Gerätetür geöffnet wird, endet das Programm. Das Gerät ist dann zur Auswahl eines neuen Programmes bereit.

### Summer einrichten

Gehen Sie zum Ändern der Summerlautstärke wie unten beschrieben vor:

1. Öffnen Sie die Tür und drücken Sie die Tasten Programm (2) und Verzögerung (4) gleichzeitig 3 Sekunden lang.

2. Wenn die Toneinstellung erkannt wird, ertönt ein langer Summer und das Display zeigt den

zuletzt eingestellten Pegel von "S0" bis "S3" an.

3. Zum Verringern der Summerlautstärke drücken Sie die

Programmtaste (2). Zum Steigern der Summerlautstärke drücken Sie die Verzögerung-Taste (4).

4. Zum Speichern der gewählten Summerlautstärke schalten Sie das Gerät aus.

„S0“ bedeutet, dass keine Tonausgabe erfolgt. Die Werkseinstellung ist S3.

### Stromsparmmodus

Gehen Sie zum Aktivieren oder Deaktivieren des Stromsparmmodus Energiesparmodus wie folgt vor:

1. Öffnen Sie die Tür und drücken Sie die Tasten Verzögerung (4) und Halbe Ladung (5) gleichzeitig 3 Sekunden lang.

2. Nach 3 Sekunden zeigt das Gerät die letzte Einstellung, "IL1" oder "IL0", an.

3. Wenn der Energiesparmodus aktiviert ist, wird "IL1" angezeigt. In diesem Modus schaltet sich die Innenbeleuchtung 4 Minuten nach dem Öffnen der Tür aus, und das Gerät schaltet sich nach 15 Minuten ohne Aktivität aus, um Energie zu sparen.

4. Bei deaktiviertem Stromsparmmodus wird „IL0“ angezeigt. Wenn der Energiesparmodus deaktiviert ist, leuchtet die Innenbeleuchtung so lange, wie die Tür geöffnet ist, und das Gerät ist immer eingeschaltet, sofern es nicht vom Benutzer ausgeschaltet wird.

5. Um die gewählte Einstellung zu speichern, schalten Sie das Gerät aus.

In der Werkseinstellung ist der Energiesparmodus aktiv.

## Infoled 2.1 GRÜN (je nach Modell)

LED-Anzeige	Zustand der Maschine
Grün, dauerleuchtend	Die Maschine führt ein Programm aus.
Grün, blinkend	Ein Programm wurde abgebrochen.
Grün, schnell blinkend	Die Maschine ist gestört. Siehe Abschnitt „ <b>Automatische Fehlerwarnungen und Abhilfemaßnahme</b> “.
Die Led geht aus	Ein Programm ist beendet.



## 8. REINIGUNG UND WARTUNG

Die Reinigung Ihres Geschirrspülers ist wichtig, um seine Lebensdauer zu sichern. Sorgen Sie dafür, dass die Wasserenthärtungseinstellung (falls vorhanden) korrekt vorgenommen und die richtige Menge an Reinigungsmittel verwendet wird, um Kalkablagerungen zu vermeiden. Füllen Sie das Salzfach nach, wenn die Salzsensorenleuchte aufleuchtet.

Im Laufe der Zeit können sich in Ihrem Geschirrspüler Fett- und Kalkablagerungen bilden. In diesem Fall:

- Füllen Sie das Waschmittelfach, aber laden Sie kein Geschirr ein. Wählen Sie ein Hochtemperaturprogramm und lassen Sie den Geschirrspüler leer laufen. Wenn Ihr Geschirrspüler dadurch nicht ausreichend gereinigt wird, verwenden Sie ein für Geschirrspüler geeignetes Reinigungsmittel.
- Um die Lebensdauer Ihres Geschirrspülers zu verlängern, reinigen Sie ihn regelmäßig einmal im Monat.
- Wischen Sie die Türdichtungen regelmäßig mit einem feuchten Tuch ab, um Rückstände oder Fremdkörper zu entfernen.

### 8.1. Filter

Reinigen Sie Filter und Sprüharme mindestens einmal pro Woche. Sind noch Speisereste am Grob- und Mikrofilter vorhanden, nehmen Sie die Filter heraus und reinigen Sie sie gründlich unter fließendem Wasser.

- a) Mikrofilter      b) Grobfilter  
c) Metallfilter

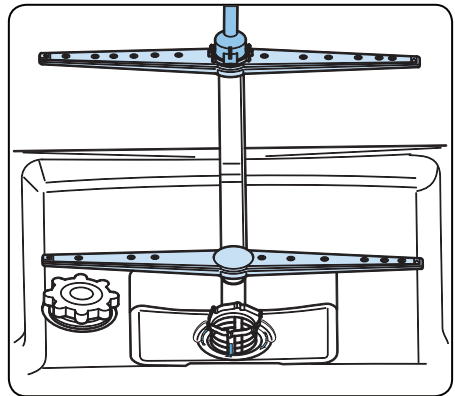
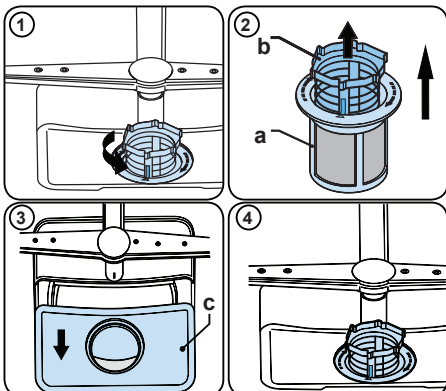

Drehen Sie die Filterkombination zum Entfernen und Reinigen gegen den Uhrzeigersinn und nehmen Sie sie durch Anheben nach oben heraus (1). Ziehen Sie den Grobfilter aus dem Mikrofilter heraus (2). Ziehen Sie dann den Metallfilter (3) heraus und entfernen Sie ihn. Spülen Sie den Filter mit viel Wasser ab, bis er frei von Rückständen ist. Bauen Sie die Filter wieder zusammen. Setzen Sie den Filtereinsatz wieder ein und arretieren Sie ihn im Uhrzeigersinn (4).

- Lassen Sie den Geschirrspüler niemals ohne die Filter laufen.
- Werden die Filter nicht richtig eingesetzt, reduziert sich die Reinigungswirkung.
- Damit die Maschine einwandfrei läuft, müssen die Filter sauber sein.

### 8.2. Sprüharme

Stellen Sie sicher, dass die Sprühlöcher nicht verstopft sind und dass keine Speisereste oder Fremdkörper an den Sprüharmen kleben. Falls es zu Verstopfungen kommt, entfernen Sie die Sprüharme und reinigen Sie sie unter Wasser. Zum Abnehmen des oberen Sprüharms lösen Sie die Mutter, die ihn in Position hält, indem Sie sie im Uhrzeigersinn drehen und nach unten ziehen. Diese Mutter muss nach dem Einsetzen des oberen Sprüharms wieder festgezogen werden.

### **8.3 Abwasserpumpe**

Große Lebensmittelreste oder Fremdkörper, die nicht von den Filtern aufgefangen wurden, können die Abwasserpumpe blockieren. Das Spülwasser steht dann höher als der Filter.

 Warnung, Gefahr von Schnittverletzungen!

Achten Sie beim Reinigen der Abwasserpumpe darauf, dass Sie sich nicht an Glasscherben oder spitzen Gegenständen verletzen.

In diesem Fall:

- 1.** Trennen Sie als Erstes das Gerät von der Stromversorgung.
- 2.** Nehmen Sie Körbe heraus.
- 3.** Entfernen Sie die Filter.
- 4.** Entfernen Sie alles Wasser, bei Bedarf mit einem Schwamm.
- 5.** Überprüfen Sie den Bereich und entfernen Sie alle Fremdkörper.
- 6.** Setzen Sie die Filter wieder ein.
- 7.** Setzen Sie die Körbe wieder ein.

## 9. FEHLERBEHEBUNG

FEHLER	MÖGLICHE URSACHE	MASSNAHME
Programm startet nicht.	Der Netzstecker des Geschirrspülers ist nicht eingesteckt.	Geschirrspüler an Stromversorgung anschließen.
	Geschirrspüler nicht eingeschaltet.	EIN/AUS-Taste drücken, um Geschirrspüler einzuschalten.
	Sicherung hat ausgelöst.	Sicherungen im Sicherungskasten prüfen.
	Zulaufwasserhahn ist geschlossen.	Zulaufwasserhahn öffnen.
	Tür des Geschirrspülers ist geöffnet.	Tür des Geschirrspülers schließen.
	Zulaufschlauch und Gerätefilter verstopft.	Zulaufschlauch und Gerätefilter auf Verstopfung prüfen.
Im Gerät bleibt Wasser zurück.	Ablaufschlauch verstopft oder verdreht.	Ablaufschlauch prüfen. Gegebenenfalls leeren oder Verdrehung lösen.
	Filter verstopft.	Filter reinigen.
	Programm ist noch nicht abgeschlossen.	Warten, bis das Programm vollständig abgearbeitet ist.
Gerät hält mitten im Programm an.	Stromausfall.	Netzstromversorgung prüfen.
	Störung bei Zulaufwasser.	Wasserhahn prüfen.
Während des Spülvorgangs sind Kippel- und Schlaggeräusch zu hören.	Sprüharm schlägt an ein Geschirrtteil im unteren Korb an.	Problematische Teile anders positionieren oder herausnehmen.
Am Geschirr bleiben Essensreste zurück.	Geschirr nicht korrekt positioniert. Betroffene Geschirrtteile werden vom Sprühwasser nicht erreicht.	Körbe nicht überladen.
	Geschirrtteile lehnen aneinander.	Hinweise im Abschnitt zum Beladen des Geschirrspülers beachten.
	Nicht genügend Spülmittel.	Korrekte Spülmittelmenge verwenden, wie in der Programmübersicht angegeben.
	Falsches Spülprogramm ausgewählt.	Wählen Sie mithilfe der Programmübersicht das optimale Programm aus.
	Sprüharme sind mit Essensresten verstopft.	Sprühöffnungen der Sprüharme mit spitzem Werkzeug reinigen.
	Filter oder Abwasserpumpe verstopft oder Filter falsch eingebaut.	Ablaufschlauch und Filter auf korrekten Sitz prüfen.

FEHLER	MÖGLICHE URSACHE	MASSNAHME
Weiße Rückstände auf dem Geschirr.	Nicht genügend Spülmittel.	Korrekte Spülmittelmenge verwenden, wie in der Programmübersicht angegeben.
	Dosierung von Klarspülmittel bzw. Wasserenthärter zu niedrig eingestellt.	Klarspülmittelmenge bzw. Wasserenthärtungsstufe erhöhen.
	Hohe Wasserhärte.	Wasserenthärtungsstufe erhöhen, Salz nachfüllen.
	Deckel des Salzbehälter nicht richtig geschlossen.	Deckel des Salzbehälter auf korrekten Sitz prüfen.
Geschirr trocknet nicht.	Keine Trocknungsoption ausgewählt.	Programm mit Trocknung auswählen.
	Klarspülmitteldosierung zu niedrig eingestellt.	Klarspülmitteldosierung erhöhen.
Rostflecken auf dem Geschirr.	Mangelhafte Edelstahlqualität.	Nur geschirrspülerfestes Geschirr/Besteck verwenden.
	Hohe Salzkonzentration im Wasser.	Wasserhärtegrad anpassen mithilfe der Wasserhärte-tabelle.
	Deckel des Salzbehälter nicht richtig geschlossen.	Deckel des Salzbehälter auf korrekten Sitz prüfen.
	Beim Nachfüllen von Salz zu viel Salz daneben geschüttet.	Beim Nachfüllen von Salz Einfülltrichter verwenden.
	Ungenügende Erdung.	Unverzüglich Elektriker kontaktieren.
In der Spülmittelkammer bleibt Spülmittel zurück.	Als das Spülmittel eingegeben wurde, war die Kammer noch feucht.	Spülmittelkammer trocknen, bevor Spülmittel eingegeben wird.

## Automatische Fehlerwarnungen und Abhilfemaßnahme

FEHLERCODE	MÖGLICHE URSACHE	ABHILFEMASSNAHME
FF	Störung des Wassereinlasssystems	Stellen Sie sicher, dass der Wasserhahn aufgedreht ist und Wasser läuft.
		Trennen Sie den Einlassschlauch vom Wasserhahn und reinigen Sie den Filter des Schlauchs.
		Wenden Sie sich an den Kundendienst, falls der Fehler weiterhin auftritt.
F5	Störung des Drucksystems	Wenden Sie sich an den Kundendienst.
F3	Wasser läuft ständig in das Gerät	Drehen Sie den Wasserhahn zu und wenden Sie sich an den Kundendienst.
F2	Wasser kann nicht abgepumpt werden	Möglicherweise sind Wasserablauschlauch oder Filter verstopft.
		Brechen Sie das Programm ab.
		Wenden Sie sich an den Kundendienst, falls der Fehler weiterhin auftritt.
F8	Heizelementfehler	Wenden Sie sich an den Kundendienst.
F1	Überlauf	Trennen Sie die Maschine vom Stromnetz, schließen Sie die Wasserzufuhr.
		Wenden Sie sich an den Kundendienst.
FE	Fehler in der Elektronik	Wenden Sie sich an den Kundendienst.
F7	Überhitzung	Wenden Sie sich an den Kundendienst.
F9	Trennelement-Position (Divisor) falsch	Wenden Sie sich an den Kundendienst.
F6	Fehlerhafter Wärmesensor	Wenden Sie sich an den Kundendienst.
HI	Spannung zu hoch	Wenden Sie sich an den Kundendienst.
LO	Spannung zu niedrig	Wenden Sie sich an den Kundendienst.

Die Installation und Reparaturen sollten nur vom autorisierten Kundendienst durchgeführt werden, um Gefahren zu vermeiden. Der Hersteller haftet nicht für Schäden, die sich aus Handlungen nicht autorisierter Personen ergeben. Reparaturen dürfen nur von autorisierten Technikern durchgeführt werden. Achten Sie darauf, dass bei Reparaturen nur Original-Ersatzteile verwendet werden.

Unsachgemäße Reparaturen oder die Verwendung von Nicht-Original-Ersatzteilen können erhebliche Schäden verursachen und den Benutzer erheblichen Gefahren aussetzen.

Die Kontaktinformationen unseres Kundendienstes finden Sie auf der Rückseite dieses Dokuments.

Funktionsrelevante Original-Ersatzteile gemäß der Ökodesign-Verordnung können für einen Zeitraum von mindestens 10 Jahren ab dem Datum, an dem Ihr Gerät im Europäischen Wirtschaftsraum in Verkehr gebracht wurde, über den Kundendienst bezogen werden.



**52397649 R60**



# HÄFELE

EN Dishwasher / User Manual

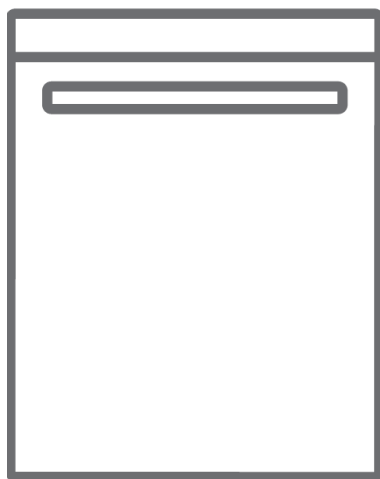





CAPELLA 533.29.501



## Thank you for choosing this product.

This user manual contains important information on safety and instructions intended to assist you in the operation and maintenance of your appliance.

Please take the time to read this user manual before using your appliance and keep this book for future reference.

Icon	Type	Meaning
	<b>WARNING</b>	Serious injury or death risk
	<b>RISK OF ELECTRIC SHOCK</b>	Dangerous voltage risk
	<b>FIRE</b>	Warning; Risk of fire / flammable materials
	<b>CAUTION</b>	Injury or property damage risk
	<b>IMPORTANT</b>	Operating the system correctly

# CONTENTS

<b>1 SAFETY INSTRUCTIONS</b> .....	<b>1</b>
1.1 General Safety Warnings .....	1
1.2 Installation Warnings .....	2
1.3 During Usage.....	3
<b>2 INSTALLATION</b> .....	<b>6</b>
2.1 Machine Positioning .....	6
2.2 Water Connection.....	6
2.3 Water Inlet Hose.....	6
2.4 Drain Hose (Model Depending).....	7
2.5 Electrical Connection.....	7
<b>3 TECHNICAL SPECIFICATIONS</b> .....	<b>8</b>
3.1 General Sppearance .....	8
3.2 Technical Specifications .....	8
<b>4 BEFORE USING THE APPLIANCE</b> .....	<b>10</b>
4.1 Preparing Your Dishwasher For First Use .....	10
4.2 Salt Usage (IF AVAILABLE).....	10
4.3 Fill The Salt (IF AVAILABLE) .....	10
4.4 Test Strip.....	11
4.5 Water Hardness Table .....	11
4.6 Water Softener System.....	11
4.7 Setting .....	11
4.8 Detergent Usage .....	11
4.9 Filling The Detergent .....	12
4.10 Using Combined Detergents .....	12
4.11 Rinse-aid Usage .....	12
4.12 Filling The rinse-aid and setting.....	12
<b>5 LOADING YOUR DISHWASHER</b> .....	<b>14</b>
5.1 Recommendations .....	14
5.2 Alternative Basket Loads .....	16
<b>6 PROGRAMME TABLE</b> .....	<b>17</b>
<b>7 THE CONTROL PANEL</b> .....	<b>18</b>
<b>8 CLEANING AND MAINTENANCE</b> .....	<b>21</b>
8.1 Filters.....	21
8.2 Spray Arms.....	21
8.3 Drain Pump.....	22
<b>9 TROUBLESHOOTING</b> .....	<b>23</b>
<b>10 THE PRODUCT FICHE</b> .....	<b>26</b>

# 1 SAFETY INSTRUCTIONS

## 1.1 General Safety Warnings

- Read these instructions carefully before using your appliance and keep this manual for future reference.

 Please check the packaging of your machine before installation and the outer surface of the machine once the packaging has been removed. Do not operate the machine if it appears damaged or if the packaging has been opened.

- Packaging materials protect your machine from any damage that might occur during transportation. The packaging materials are environmentally friendly as they are recyclable. Use of recycled material reduces raw material consumption and decreases waste production.

 This appliance can be used by children aged from 8 years and above, and by persons with reduced physical, sensory or mental capabilities or lack of experience and knowledge if they have been given supervision or instruction concerning the use of the appliance in a safe way and understand hazards involved. Children should not be allowed to play with the appliance.

 Remove packaging and keep it out of reach of children.

 Keep children away from detergents and rinse aids.

 There may be some residue left in the machine after washing. Keep children away from the machine when it is open.

## 1.2 Installation Warnings



- Choose a suitable and safe place to install your machine.
- Only original spare parts should be used with the machine.

  Unplug the machine before installation.

 Your machine must only be installed by an authorised service agent. Installation by anyone other than an authorised agent may cause your warranty to be void.

 Check that the indoor electrical fuse system is connected in line with safety regulations.



 All electrical connections must match the values on the plate.

  Ensure the machine does not stand on the electrical supply cable.



 Never use an extension cord or a multiple socket connection.

 The plug should be accessible after the machine is installed.

- After installation, run your machine unloaded for the first time.

  The machine must not be plugged in during positioning.

 Always use the coated plug supplied with your machine.

  If the electrical cable is damaged, it should only be replaced by a qualified electrician.

- Connect the hose directly to the water inlet tap. The pressure supplied by the tap should be a minimum of 0.03 MPa and a maximum of 1 MPa. If the pressure exceeds 1 MPa, a pressure relief valve must be fitted between the connection.

### **1.3 During Usage**

- This machine is for domestic use only; do not use it for other purposes. Commercial use will void the guarantee.

 Do not stand, sit or place loads on the open door the dishwasher.

 Only use detergents and rinse aids produced specifically for dishwashers. Our company is not responsible for any damage that may occur due to misuse.

 Do not drink water from the machine.

 Due to the danger of explosion, do not place any chemical dissolving agents into the machine's washing section.



- Check the heat-resistance of plastic items before washing them in the machine.

 Only put items in the machine which are suitable for dishwashing, and take care not to overfill the baskets.



 Do not open the door while the machine is in operation, hot water may spill out. Safety devices ensure the machine stops if the door is opened.

 The machine door should not be left open. It may cause accidents.

 Place knives and other sharp objects in the cutlery basket in a blade-down position.

  For models with the automatic door-opening system, when the EnergySave option is active, the door will open at the end of a program. To prevent damage to your dishwasher, do not attempt to close the door for one minute after it has opened. For effective drying, keep the door open for 30 minutes after a programme has ended. Do not stand in front of the door after the auto-open signal sounds.

 In the case of a malfunction, repair should only be performed by an authorised service company, otherwise the warranty will be void.

  Before repair work, the machine should be disconnected from the mains. Do not pull the cable to unplug the machine. Switch off the water tap.

 Operation at a low voltage will cause a decline in performance levels.

 For safety, disconnect the plug once a program has finished.

 To avoid an electric shock, do not unplug the machine with wet hands.

 Pull the plug to disconnect the machine from the mains, never pull on the cord.

## 2 INSTALLATION

### 2.1 Machine Positioning

When positioning the machine, place it in an area where dishes can be easily loaded and unloaded. Do not put the machine in an area where the ambient temperature falls below 0°C.

Read all warnings located on the packaging before removing the packaging and positioning the machine.

Place the machine close to a water tap and drain. Take into consideration that the connections will not be altered once the machine is in position.

Do not hold the machine by its door or panel.

Leave an adequate distance around the machine to allow ease of movement when cleaning.

 Ensure the water inlet and outlet hoses are not squeezed or trapped and that the machine does not stand on the electrical cable while positioning.

Adjust the feet so the machine is level and balanced. The machine should be placed on flat ground otherwise it will be unstable and the door of the machine will not close properly.

 Please install the decorative panel as indicated on the assembly sheet. Otherwise, the door may not open properly and steam leakage problem may occur.

### 2.2 Water Connection

We recommend fitting a filter to your water inlet supply in order to prevent damage to your machine due to contamination (sand, rust, etc.) from indoor plumbing. This will also help prevent yellowing and deposit formation after washing.

Note printing on the water inlet hose!  
If models are marked with 25°, the water temperature may be max. 25 °C (cold

water).

For all other models:

Cold water preferred; hot water max. temperature 60 °C.

### 2.3 Water Inlet Hose





 **WARNING:** Use the new water inlet hose supplied with your machine, do not use an old machine's hose.

 **WARNING:** Run water through the new hose before connecting.

 **WARNING:** Connect the hose directly to the water inlet tap. The pressure supplied by the tap should be a minimum of 0.03 MPa and a maximum of 1 MPa. If the pressure exceeds 1 MPa, a pressure relief valve must be fitted between the connection.

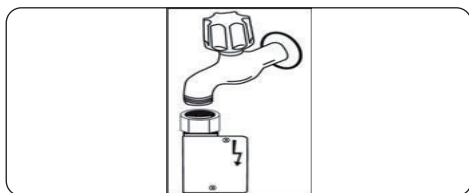
 **WARNING:** After the connections are made, turn the tap on fully and check for water leaks. Always turn off the water inlet tap after a wash program has finished.



 An Aquastop water spout is available with some models. Do not damage it or allow it to become kinked or twisted.



## 2.4 Drain Hose (Model Depending)

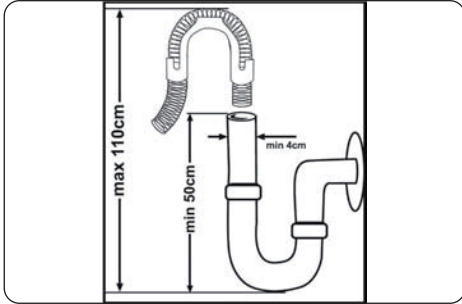

Connect the water drain hose directly to water drain hole or to the sink outlet spigot. This connection should be minimum 50 cm and maximum 110 cm from floor that dishwasher is placed.



**IMPORTANT:** Items will not wash properly if a drain hose longer than 4 m is used.

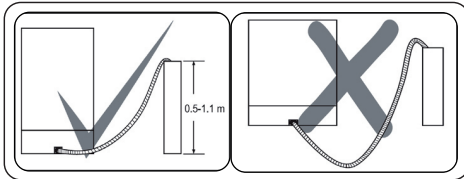

## 2.5 Electrical Connection



**WARNING:** Your machine is set to operate at 220-240 V. If the mains voltage supply to your machine is 110 V, connect a transformer of 110/220 V and 3000 W between the electrical connection.



Connect the product to a grounded outlet protected by a fuse complying with the values in the “Technical Specifications” table”.



The earthed plug of the machine must be connected to an earthed outlet supplied by suitable voltage and current.



In the absence of earthing installation, an authorised electrician should carry out an earthing installation. In the case of use without earthing installed, we will not be responsible for any loss of use that may occur.



The plug on this appliance may incorporate 13A fuse depending on the target country. (For Example UK, Saudi Arabia)

### 3 TECHNICAL SPECIFICATIONS

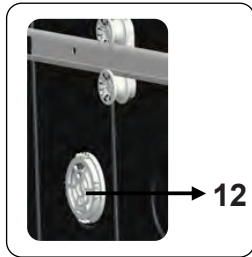
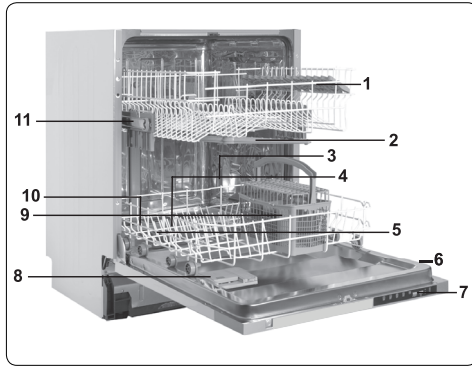

#### 3.1 General Appearance

1. Upper basket with racks
2. Upper spray arm
3. Lower basket
4. Lower spray arm
5. Filters
6. Rating plate
7. Control panel
8. Detergent and rinse-aid dispenser
9. Cutlery basket
10. Salt dispenser
11. Upper basket track latch
12. **Mini Active Drying Unit:** This system provides better drying performance your dishes.

#### 3.2 Technical Specifications

Capacity	12 place settings
Dimensions	
Height	820-870 (mm)
Width	598 (mm)
Depth	570 (mm)
Net weight	31,400 kg
Operating voltage / frequency	220-240V 50 Hz
Total current	10(A)
Total power	1900(W)
Water supply pressure	Maximum: 1 (Mpa) Minimum: 0.03 (Mpa)

## RECYCLING

- Some machine components and packaging consist of recyclable materials.
- Plastics are marked with the international abbreviations: (>PE<, >PP<, etc. )
- The cardboard parts consist of recycled paper. They can be put into waste paper containers for recycling.
- Material unsuitable for domestic waste must be disposed of at recycling centres.
- Contact a relevant recycling centre to obtain information about disposal of different materials.

## PACKAGING AND THE ENVIRONMENT

- Packaging materials protect your machine from damage that may occur during transportation. The packaging materials are environmentally friendly as they are recyclable. The use of recycled material reduces raw material consumption and therefore decreases waste production.

## CE Declaration of Conformity

We declare that our products meet the applicable European Directives, Decisions and Regulations and the requirements listed in the standards referenced.

## Disposal of Your Old Machine



The symbol on the product or on its packaging indicates that this product may not be treated as household waste. Instead, it shall be taken to the applicable collection point for the recycling of electrical and electronic equipment. By ensuring

this product is disposed of correctly, you will help prevent potential negative consequences for the environment and human health, which could otherwise be caused by inappropriate waste handling of this product. For more detailed information about recycling this product, please contact your local city office, your household waste disposal service or the shop where the product was purchased.

## 4 BEFORE USING THE APPLIANCE

### 4.1 Preparing Your Dishwasher For First Use

- Make sure the electricity and supply water specifications match the values indicated in the installation instructions for the machine.
- Remove all packaging material inside the machine.
- Set the water softener level.
- Fill the rinse aid compartment..

### 4.2 Salt Usage (IF AVAILABLE)

For a good washing function, the dishwasher needs soft, i.e. less calcareous water. Otherwise, White lime residues will remain on the dishes and the interior equipment. This will negatively affect your machine's washing, drying and shining performance. When water flows through the softener system, the ions forming the hardness are removed from the water and the water reaches the softness required to obtain the best washing result. Depending on the level of hardness of the inflowing water, these ions that harden the water accumulate rapidly inside the softener system. Therefore, the softener system has to be refreshed so that it operates with the same performance also during the next wash. For this purpose, dishwasher salt is used.

Machine can only be used by special dishwasher salt to soften the water. Do not use any small grained or powdered type of salts which can easily soluble. Using any other type of salt can damage your machine.

### 4.3 Fill The Salt (IF AVAILABLE)

To add softener salt, open the salt compartment cap by turning it counter clockwise. **(1)** **(2)** At first use, fill the compartment with 1 kg salt and water **(3)** until it is almost overflowing. If available, using a funnel **(4)** will make filling easier. Replace the cap and close it. After every 20-30 Cycles add salt into your machine until it fills up (approx. 1 kg).

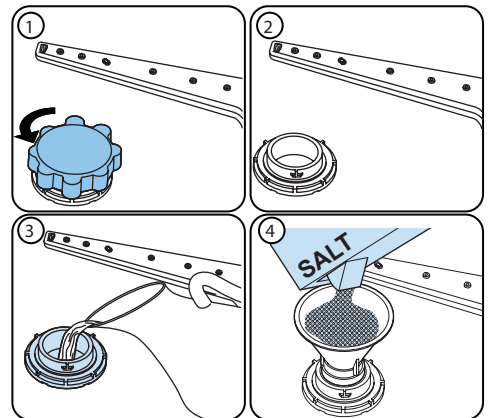

#### Only add water to the salt compartment on first use.

Use softener salt specifically produced for use in dishwashers.

When you start your dishwasher, the salt compartment is filled with water, therefore put the softener salt in prior to starting your machine.

If the softener salt has overflowed and you do not start the machine immediately, run a short washing program to protect your machine against corrosion.

## 4.4 Test Strip

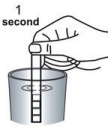
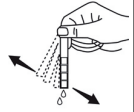
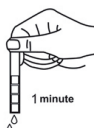
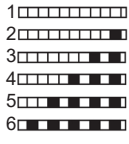
Run water through the tap (1min.)	Keep the strip in the water (1sec)	Shake the strip.	Wait (1min.)	Set the hardness level of your machine.
				

**NOTE:** The level is set to 3 as default. If the water is well water or has a hardness level above 90 dF, we recommend that you use filter and refinement devices.

## 4.5 Water Hardness Table

Level	German dH	French dF	British dE	Indicator
1	0-5	0-9	0-6	L1 is shown on the display.
2	6-11	10-20	7-14	L2 is shown on the display.
3	12-17	21-30	15-21	L3 is shown on the display.
4	18-22	31-40	22-28	L4 is shown on the display.
5	23-34	41-60	29-42	L5 is shown on the display.
6	35-50	61-90	43-63	L6 is shown on the display.

## 4.6 Water Softener System

The dishwasher is equipped with a water softener which reduces the hardness in the mains water supply. To find out the hardness level of your tap water, contact your water company or use a test strip (if available).

## 4.7 Setting

- Open the door of the machine.
- Turn on the machine, and press the Programme button as soon as the machine is turned on.
- Hold down the Programme button until “SL” disappears.
- The machine will display the last setting.
- Set the level by pressing the Programme button.
- Turn off the machine to save the setting.

## 4.8 Detergent Usage

Only use detergents specifically designed for domestic dishwashers. Keep your detergents in cool, dry places out of reach of children.

Add the proper detergent for the selected program to ensure the best performance. The amount of detergent needed depends on the cycle, load size, and soil level of dishes.

Do not fill detergent into the detergent compartment more than required; otherwise you can see whitish streaks or bluish layers on glass and dishes and may cause glass corrosion. Continued use of too much detergent may cause machine damage.

Using little detergent can result in poor cleaning and you can see whitish streaks in hard water.

See the detergent manufacturer's instructions for a further information.

#### 4.9 Filling The Detergent

Push the latch to open the dispenser and pour in the detergent.

Close the lid and press it until it locks in place. The dispenser should be refilled just before the start of each programme. If the dishes are heavily soiled, place additional detergent in the pre-wash detergent chamber.

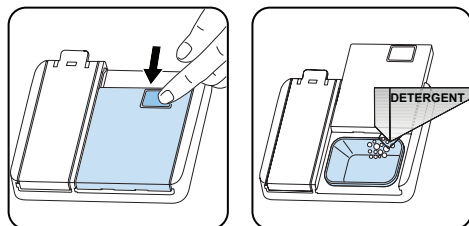

#### 4.10 Using Combined Detergents

These products should be used according to the manufacturer's instructions.

Never put combined detergents into the interior section or the cutlery basket.

Combined detergents contain not only the detergent but also rinse-aid, salt replacement substances and additional components depending on the combination.

We recommend you do not use combined detergents in short programmes.

Please use powder detergents in such programmes.

If you encounter problems when using combined detergents, please contact the detergent manufacturer.

When you stop using combined detergents, make sure that water hardness and rinse aid settings are set to the correct level.

#### 4.11 Rinse-aid Usage

The rinse aid helps to dry the dishes without streaks and stains. Rinse-aid is required for stain-free utensils and clear glasses. The rinse aid is automatically released during the hot rinse phase. If rinse aid dosage setting set too low, whitish stains remains on dishes and dishes do not dry and washed clean.

If rinse aid dosage setting set too height, you can see bluish layers on glass and dishes.

#### 4.12 Filling The rinse-aid and setting

To fill the rinse aid compartment, open the rinse-aid compartment cap. Fill the compartment with rinse aid to the MAX level and then close the cap. Be careful not to overfill the rinse aid compartment and wipe up any spills.

**In order to change the rinse aid level, follow the below steps before turning on the machine:**

- Open the door of the machine.
- Turn on the machine, and press the Programme button as soon as the machine is turned on.
- Hold down the Programme button until "rA" disappears. Rinse aid setting follows water hardness setting.
- The machine will display the last setting.
- Change the level by pressing the programme button.
- Turn off the machine to save the setting.

The factory setting is "4".

If the dishes are not drying properly or are spotted, increase the level. If blue stains form on your dishes, decrease the level.

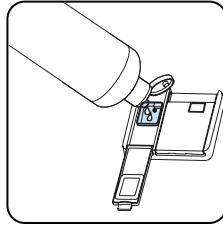
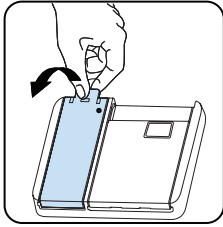

Level	Brightener Dose	Indicator
1	Rinse-aid not dispensed	r1 is shown on the display.
2	1 dose is dispensed	r2 is shown on the display.
3	2 doses are dispensed	r3 is shown on the display.
4	3 doses are dispensed	r4 is shown on the display.
5	4 doses are dispensed	r5 is shown on the display.

## 5 LOADING YOUR DISHWASHER

For best results, follow these loading guidelines.

Loading the household dishwasher up to the capacity indicated by the manufacturer will contribute to energy and water savings.

Manual pre-rinsing of tableware items leads to increased water and energy consumption and is not recommended. You can place cups, glasses, stemware, small plates, bowls, etc. in upper basket. Do not lean long glasses against one another or they cannot remain steady and may receive damage.

When placing long stem glasses and goblets, lean them against the basket edge or rack and not against other items.

Place all containers such as cups, glasses and pots into the dishwasher with the opening facing downwards otherwise water can collect on items.

If there is cutlery basket in machine, you are recommended to use the cutlery grid in order to obtain the best result. Place all large (pots, pans, lids, plates, bowls etc.) and very dirty items in the lower rack.

Dishes and cutlery should not be placed above each other.



**WARNING:** Take care not to obstruct the rotation of spray arms.



**WARNING:** Make sure after loading the dishes do not prevent opening the detergent dispenser.

### 5.1 Recommendations

Remove any coarse residue on dishes before placing the dishes in the machine. Start the machine with full load.



Do not overload the drawers or place dishes in the wrong basket.



**WARNING:** To avoid any possible injuries, place long-handle and sharp-pointed knives with their sharp points facing down or horizontally on the baskets.



### Upper Basket Height Adjustment When Full

The upper basket includes a mechanism that allows the height of the basket to be adjusted to the upper (1), lower (2) or middle (3) position without having to remove the basket. Grasp the basket on both sides and pull it up or down, ensuring that both sides of the upper basket are in the same position.

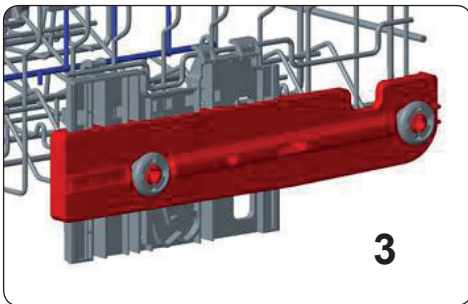
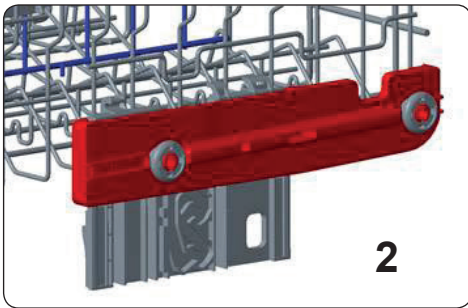
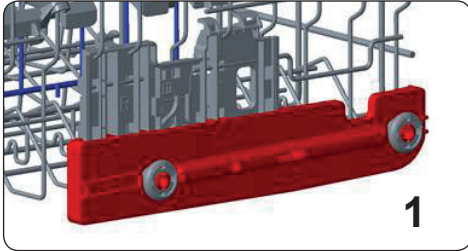

### Height Adjustable Rack (peg type)

The height adjustable racks enable glasses and cups to be placed on or under the racks. The racks can be adjusted to 2 different heights. Cutlery and utensils can also be placed on the racks horizontally.

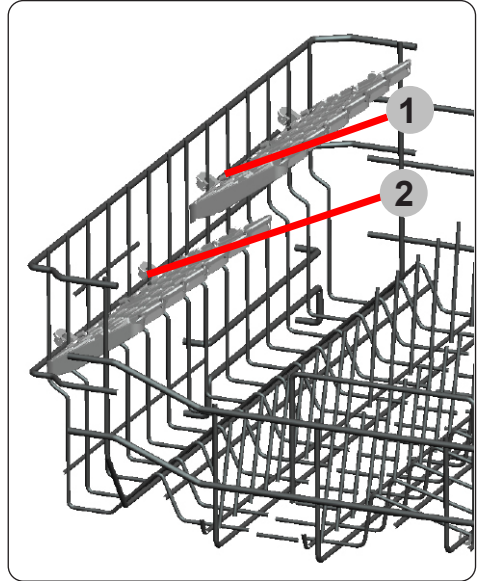

## 5.2 Alternative Basket Loads

### Lower Basket

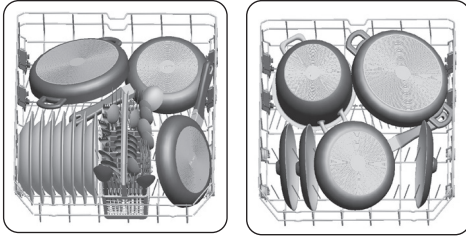

### Upper Basket

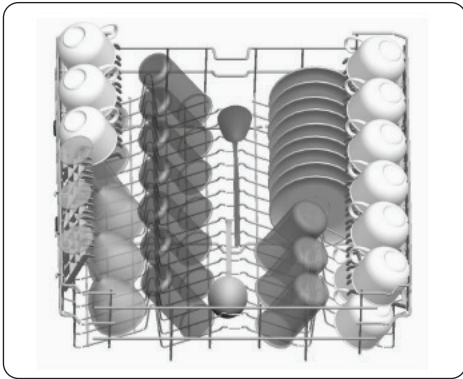

### Incorrect Loads

Incorrect loading can cause poor washing and drying performance. Please follow the manufacturer's recommendations for a good performance result.

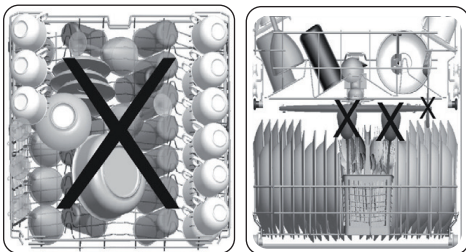

## Unsuitable Items For Dishwashing

- Cigarette ashes, candle leftovers, polish, paint, chemical substances, iron-alloy materials.
- Forks, spoons and knives with wooden, bone, ivory or nacrecoated handles; glued items, items soiled with abrasive, acidic or base chemicals.
- Temperature-sensitive plastics, copper or tincoated containers.
- Aluminium and silver objects.
- Some delicate glasses, ornamental printed porcelains; some crystal items, adhered cutlery, lead crystal glasses, cutting boards, synthetic fibred items.
- Absorbent items such as sponges or kitchen rugs.



**IMPORTANT:** In future, purchase dishwasher-proof kitchenware.

### Important Note for Test Laboratories

For detailed information required for tests according to EN normatives and a softcopy of the manual, please send the model name and serial number to the following address: [dishwasher@standardtest.info](mailto:dishwasher@standardtest.info)

## 6 PROGRAMME TABLE

	P1	P2		P3	P4	P5	P6
Program Name:	Eco	Intensive 65°C	Auto	Hygiene 70°C	Super 50'	Quick 30'	Prewash
Type of Soil:	Standard program for normally soiled daily using dishes with reduced energy and water consumptions.	Suitable for heavily soiled dishes.	Auto program for heavily soiled dishes.	Suitable for heavily soiled dishes requiring hygienic washing.	Suitable for normally soiled daily dishes with faster program.	Suitable for lightly soiled dishes and quick wash.	Suitable to rinse dishes that you plan to wash later.
Level of Soil:	Medium	Heavy	Heavy	Heavy	Medium	Light	Light
Amount of Detergent: A: 25 cm <sup>3</sup> B: 15 cm <sup>3</sup> *	A	A	A	A	A	A	-
Program Duration (h:min)	03:25	01:57	01:25 - 01:57	02:07	00:50	00:30	00:15
Electricity consumption (kWh/cycle)	0.923	1.700	1.450 - 1.700	1.900	1.100	0.740	0.020
Water consumption (l/cycle)	12.0	17.2	11.9 - 17.2	16.0	12.0	12.4	4.5

- The program duration may change according to the amount of dishes, the water temperature, the ambient temperature and selected additional functions.
- Values given for programmes other than the eco programme are indicative only
- If your model has turbidity sensor, it has Auto program instead of Intensive program.
- Eco programme is suitable to clean normally soiled tableware, that for this use, it is the most efficient programme in terms of its combined energy and water consumption, and that it is used to assess compliance with the EU ecodesign legislation.
- Washing tableware in a household dishwasher usually consumes less energy and water in the use phase than hand dishwashing when the household dishwasher is used according to the manufacturer's instructions.
- Only use powder detergent for short programs.
- Short programs do not include drying.
- To assist drying, we recommend slightly opening the door after a cycle is complete.
- You can access the product database where the model information is stored by reading the QR code on the energy label.



**NOTE:** According to regulations 1016/2010 and 1059/2010, Eco program energy consumption values may differ. This table is in line with regulations 2019/2022 and 2017/2022.

## 7 THE CONTROL PANEL

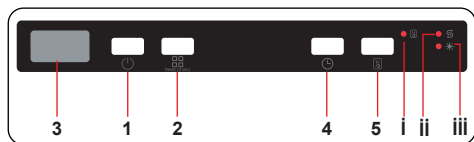

1. On/Off button
2. Program Selection Button
3. Display
4. Delay Button
5. Half Load Button
- i. Half Load Led
- ii. Salt Indicator
- iii. Rinse Aid Indicator

### 1. On/Off Button

Switch the machine on by pressing On / Off button. When machine is on, "--" will be shown on the Display (3).

### 2. Program Selection Button

Select a suitable programme for your dishes by pressing Program Selection button. The programme will start automatically when the door is closed.

### 3. Display

The Display shows the number and total time of the selected programme alternately and the remaining time during operation.

### 4. Delay Button

Press the Delay button to delay the start time of the selected programme for 1 hour up to 19 hours. Pressing the button once delays the start time for 1 hour, and continuing to press will increase the delay time. Press the Delay button to change or cancel the delayed start. If you switch off the machine while delay timer is active, the delayed time is cancelled.

### 5. Half Load Button

Press the Half Load button to reduce the duration of the selected programme, and therefore decrease your energy and water

consumption. When Half Load option is selected, Half Load led (i) will illuminate.

 **NOTE:** If you decide not to start the selected programme, please see the "Changing a Programme" and "Cancelling a Programme" sections.

 **NOTE:** When there is insufficient softening salt, the Salt Lack Warning Indicator (ii) will illuminate to indicate the salt chamber needs filling.

 **NOTE:** When there is insufficient rinse aid, the Rinse Aid Lack Warning Indicator (iii) will illuminate to indicate the rinse aid chamber needs filling.

### Changing a Programme

Follow the steps below if you would like to change the programme while in operation.

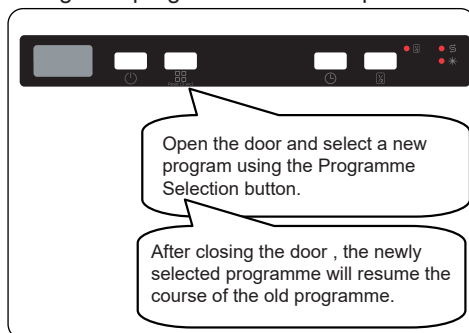

 **NOTE:** Open the door slightly at first to avoid water spillage if you wish to stop the wash programme before it is complete

## Canceling a Programme

Follow the steps below if you would like to cancel a programme while in operation.

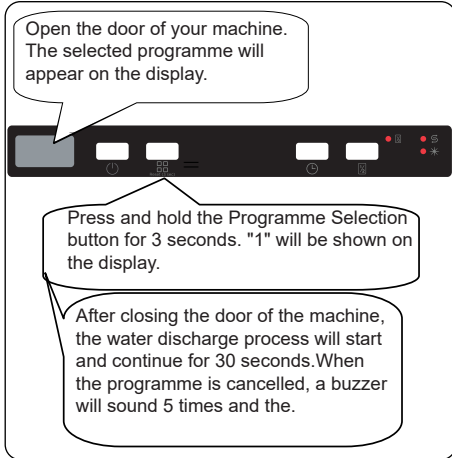

## Switching the Machine Off

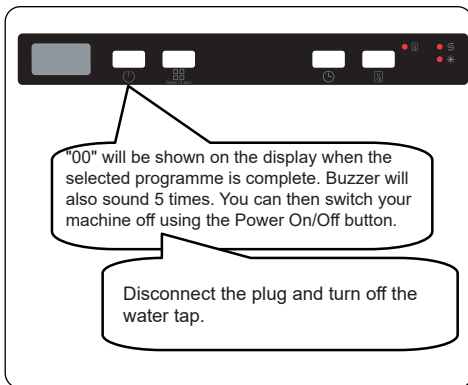

**NOTE:** Do not open the door before the programme is complete.

**NOTE:** If the door of the machine is opened or the power is cut off while a programme is in operation, the programme will continue when the door is closed or the power returns.

**NOTE:** If the power is cut or the machine door is opened during the drying process, the programme will terminate. Your machine will now be ready for a new programme selection.

**NOTE:** Buzzer sounds 5 times each at 5 minutes intervals (in 0, 5, 10 and 15th minutes) in total 4 different times at the end of the program.

## Buzzer Sound Control

To change the buzzer sound level, follow the below steps:

1. Open the door and press Programme (2) and Delay (4) buttons simultaneously for 3 seconds.
2. When sound setting is recognized, buzzer gives a long sound and machine will display last set level, from "S0" to "S3".
3. To decrease sound level press Programme button (2). To increase sound level, press Delay button (4).
4. To save the selected sound level, turn off the machine.

"S0" level means all voices are off. Factory setting is "S3".

## Save Power Mode

To activate or deactivate save power mode, follow the below steps:

1. Open the door and press Delay (4) and Half Load (5) buttons simultaneously for 3 seconds.
2. After 3 seconds, the machine will display last Setting, "IL1" or "IL0".
3. When Save Power Mode is activated, "IL1" will be displayed. On this mode, interior lights will turn off 4 minutes after the door is opened, and the machine will turn off after 15 minutes of no activity in order to save energy.
4. When Save Power Mode is deactivated "IL0" will be displayed. If Save Power Mode is deactive, interior lights will be on as long as the door is open, and the machine will always be on unless it is turned off by user.
5. To save the selected setting, turn off the machine.

In factory setting, Save Power Mode is active.

### Infoled 2.1 (Model Dependent)

<b>LED Indicator</b>	<b>State of the Machine</b>
Red, continuous	The machine is running a program.
Red, flashing	A program is cancelled.
Red, flashing rapidly	The machine has a fault. Refer to section " <b>Automatic fault warnings and what to do</b> ".
Green, continuous	A program is finished.

## 8 CLEANING AND MAINTENANCE

Cleaning your dishwasher is important to maintain the machine's service life

Make sure that the water softening setting (If available) is done correctly and correct amount of detergent is used to prevent limescale accumulation. Refill the salt compartment when the salt sensor light comes on. Oil and limescale may build up in your Dishwasher over time. If this occurs:

- Fill the detergent compartment but do not load any dishes. Select a programme which runs at high temperature and run the Dishwasher empty. If this does not clean your Dishwasher sufficiently, use a cleaning agent designed for use with dishwashers.
- To extend the life of your dishwasher, clean the appliance regularly on each month
- Wipe the door seals regularly with a damp cloth to remove any accumulated residue or foreign objects.

### 8.1 Filters

Clean the filters and spray arms at least once a week. If any food waste remains or foreign objects on the coarse and fine filters, remove them and clean them thoroughly with water.

- a) Micro Filter   b) Coarse Filter  
c) Metal Filter

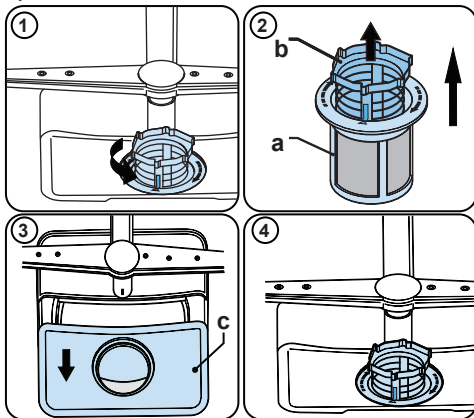

To remove and clean the filter combination, turn it counter clockwise and remove it by lifting it upwards **(1)**. Pull the coarse filter out of the micro filter **(2)**. Then pull and remove the metal filter **(3)**. Rinse the filter with lots of water until it is free of residue. Reassemble the filters. Replace the filter insert, and rotate it clockwise **(4)**.

- Never use your dishwasher without a filter.
- Incorrect fitting of the filter will reduce the washing effectiveness.
- Clean filters are necessary for proper running of the machine.

### 8.2 Spray Arms

Make sure that the spray holes are not clogged and that no food waste or foreign object is stuck to the spray arms. If there is any clogging, remove the spray arms and clean them under water. To remove the upper spray arm undo the nut holding it in position by turning it clockwise and pulling it downwards. Make sure that the nut is properly tightened when refitting the upper spray arm.

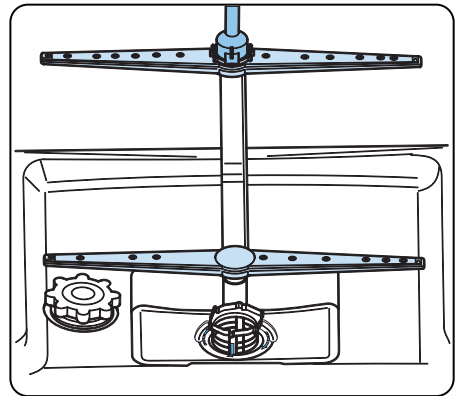

### 8.3 Drain Pump

Large food residues or foreign objects which were not captured by the filters may block the waste water pump. The rinsing water will then be above the filter.

 Warning Risk of cuts!

When cleaning the waste water pump, ensure that you do not injure yourself on pieces of broken glass or pointed implements.

In this case:

1. First always disconnect the appliance from the power supply.
2. Take out baskets.
3. Remove the filters.
4. Scoop out water, use a sponge if required.
5. Check the area and remove any foreign objects.
6. Install filters.
7. Re-insert baskets.



## 9 TROUBLESHOOTING

FAULT	POSSIBLE CAUSE	TROUBLESHOOTING
The programme does not start.	Your Dishwasher is not plugged in.	Plug your Dishwasher in.
	Your Dishwasher is not switched on.	Switch your Dishwasher on by pressing the On/Off button.
	Fuse blown.	Check your indoor fuses.
	Water inlet tap is closed.	Turn on the water inlet tap.
	Your Dishwasher door is open.	Close the Dishwasher door.
	Water inlet hose and machine filters are clogged.	Check the water inlet hose and machine filters and make sure they are not clogged.
Water remains inside the machine.	Water drain hose is clogged or twisted.	Check the drain hose, then either clean or untwist it.
	The filters are clogged.	Clean the filters.
	The programme is not finished yet.	Wait until the programme is finished.
Machine stops during washing.	Power failure.	Check mains power.
	Water inlet failure.	Check water tap.
Shaking and hitting noises are heard during a wash operation.	The spray arm is hitting the dishes in the lower basket.	Move or remove items blocking the spray arm.
Partial food wastes remain on the dishes.	Dishes placed incorrectly, sprayed water not reaching affected dishes.	Do not overload baskets.
	Dishes leaning each another.	Place dishes as instructed in the section on loading your dishwasher.
	Not enough detergent used.	Use the correct amount of detergent, as instructed in the programme table.
	Wrong wash programme selected.	Use the information in the programme table to select the most appropriate programme.
	Spray arms clogged with food waste.	Clean the holes in the spray arms with thin objects.
	Filters or water drain pump clogged or filter misplaced.	Check the drain hose and filters are correctly fitted.

FAULT	POSSIBLE CAUSE	TROUBLESHOOTING
Whitish stains remains on dishes.	Not enough detergent used.	Use the correct amount of detergent, as instructed in the programme table.
	Rinse aid dosage and/or water softener setting set too low.	Increase rinse aid and/or water softener level.
	High water hardness level.	Increase water softener level and add salt.
	Salt compartment cap not closed properly.	Check that the salt compartment cap is closed properly.
Dishes do not dry.	Drying option is not selected.	Select a programme with a drying option.
	Rinse aid dosage set too low.	Increase rinse aid dosage setting.
Rust stains form on the dishes.	Stainless-steel quality of the dishes is insufficient.	Use only dishwasher-proof sets.
	High level of salt in wash water.	Adjust the water hardness level using water hardness table.
	Salt compartment cap not closed properly.	Check that the salt compartment cap is closed properly.
	Too much salt spilled in the Dishwasher while filling it with salt.	Use funnel while filling salt to the compartment to avoid spillage.
	A poor mains grounding.	Consult a qualified electrician immediately.
Detergent remains in the detergent compartment.	Detergent was added when the detergent compartment was wet.	Make sure detergent compartment is dry before use.

## AUTOMATIC FAULT WARNINGS AND WHAT TO DO

TROUBLE CODE	POSSIBLE FAULT	WHAT TO DO
FF	Water inlet system failure	Make sure the water inlet tap is open and water is flowing.
		Separate the inlet hose from the tap and clean the filter of the hose.
		Contact for service if the error continues.
F5	Pressure system failure	Contact for service.
F3	Continuous water input	Close the tap and contact for service.
F2	Inability to discharge water	Water discharge hose and filters may be clogged.
		Cancel the program.
		If the error continues, contact for service.
F8	Heater error	Contact for service.
F1	Overflow	Unplug the machine and close the tap.
		Contact for service.
FE	Faulty electronic card	Contact for service.
F7	Overheating	Contact for service.
F6	Faulty heater sensor	Contact for service.
HI	High voltage failure	Contact for service.
LO	Low voltage failure	Contact for service.

The installation and repairing procedures should always be carried out by the Authorised Service Agent in order to avoid possible risks. The manufacturer shall not be held liable for damages that may arise from procedures carried out by unauthorised persons. Repairs may be carried out by technicians only. If a component has to be replaced, ensure that only original spare parts are used.

Improper repairs or use of non-original spare parts may cause considerable damage and put the user at considerable risk.

Contact information for your customer service can be found on the back of this document. Function-relevant genuine spare parts according to the corresponding Ecodesign order can be obtained from Customer Service for a period of at least 10 years from the date on which your appliance was placed on the market within the European Economic Area.

**CE**



**XXXXX**



# HÄFELE

TR Bulaşık Makinesi / Kullanım Kılavuzu

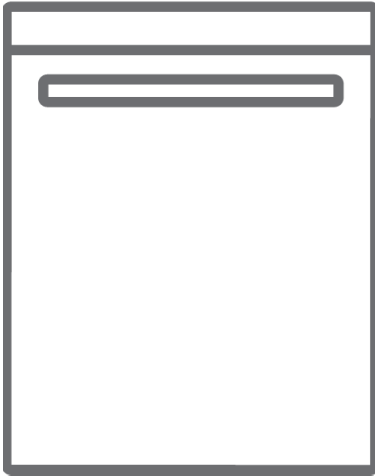

CAPELLA 533.29.501

**Bu ürünü seçtiğiniz için teşekkürler.**

Bu kullanım kılavuzu, önemli güvenlik bilgilerinin yanı sıra cihazın çalıştırılması ve bakımı için talimatlar içermektedir.

Cihazı kullanmadan önce bu kullanım kılavuzunu okumak için zaman ayırın ve ileride başvurmak üzere saklayın.

Simge	Tip	Önemi
	UYARI	Ciddi yaralanma veya ölüm riski
	ELEKTRİK ÇARPMASI RİSKİ	Tehlikeli voltaj riski
	ATEŞ	Uyarı; Yangın / yanıcı malzeme riski.
	DİKKAT	Yaralanma veya mal hasarı riski
	ÖNEMLİ / NOT	Sistemi doğru şekilde çalıştırma

# İÇİNDEKİLER

<b>1. GÜVENLİK TALİMATLARI</b> .....	<b>1</b>
1.1. Genel Güvenlik Talimatları.....	1
1.2. Kurulumla İlgili Uyarılar.....	2
1.3. Kullanım Sırasında .....	3
<b>2. KURULUM</b> .....	<b>6</b>
2.1. Makinenin Konumlandırılması .....	6
2.2. Su Bağlantısı .....	6
2.3. Su Giriş Hortumu .....	6
2.4. Tahliye Hortumu (Modele Bağlı) .....	7
2.5. Elektrik Bağlantısı .....	7
<b>3 TEKNİK ÖZELLİKLER</b> .....	<b>8</b>
3.1. Genel Görünüm .....	8
3.2. Teknik Özellikler.....	8
<b>4.CİHAZI KULLANMADAN ÖNCE</b> .....	<b>10</b>
4.1.Bulaşık Makinenizi İlk Kullanıma Hazırlama .....	10
4.2. Tuz Kullanımı (VARSA) .....	10
4.3. Tuz doldurun (VARSA). .....	10
4.4. Test Şeridi .....	11
4.5. Su Sertliği Tablosu .....	11
4.6. Su Yumuşatıcı Sistem.....	11
4.7.Ayar .....	11
4.8. Deterjan Kullanımı .....	12
4.9. Deterjan Dolumu.....	12
4.10.Hepsi Bir Arada Deterjanlar .....	12
4.11. Parlaticı Kullanımı .....	12
4.12.Parlaticı Dolumu ve Ayarı .....	12
<b>5.BULAŞIK MAKİNESİNİN YÜKLENMESİ</b> .....	<b>14</b>
5.1. Öneriler .....	14
5.2. Alternatif Sepet .....	16
<b>6.PROGRAM TABLOSU</b> .....	<b>17</b>
<b>7.KONTROL PANELİ</b> .....	<b>18</b>
<b>8.TEMİZLİK VE BAKIM</b> .....	<b>21</b>
8.1. Filtreler.....	21
8.2. Püskürtme Kolları .....	21
8.3. Tahliye Pompası .....	22
<b>9.SORUN GİDERME</b> .....	<b>23</b>

# 1 GÜVENLİK TALİMATLARI

## 1.1 Genel Güvenlik Talimatları

- Cihazınızı kullanmadan önce bu talimatları dikkati bir şekilde okuyun ve bu kılavuzu ileride başvurmak üzere saklayın.

 Lütfen kurulumdan önce makinenizin ambalajını, ambalajı çıkardıktan sonra da dış yüzeyini kontrol edin. Makinede hasar varsa veya ambalaj açılmışsa makineyi çalıştırmayın.

- Ambalaj malzemeleri, makinenizi taşıma sırasında meydana gelebilecek hasarlara karşı korur. Ambalaj malzemeleri geri dönüştürülebilir olduğu için çevre dostudur. Geri dönüştürülmüş malzeme kullanımı, ham madde tüketimini ve atık üretimini azaltır.

 Bu ürün, denetim altında tutulmaları ya da ürünün güvenli kullanımına dair talimatların kendilerine verilmiş olması ve ilgili tehlikeleri anlamış olmaları koşuluyla 8 yaş ve üzeri çocuklar ile fiziksel, duyuşsal veya zihinsel becerileri sınırlı olan ya da bilgi ve tecrübe eksikliği bulunan kişiler tarafından kullanılabilir. Çocukların cihazla oynamasına izin verilmemelidir.

 Ambalajı çıkarın ve çocukların ulaşamayacağı bir yerde saklayın.

 Çocuklarınızı deterjan ve parlaticı maddelerden uzak tutun.





 Yıkama sonrasında makinede kalıntı bulunabilir. Makine açıkken çocukları makineden uzak tutun.

## 1.2 Kurulumla İlgili Uyarılar

- Makinenizi kurmak için uygun ve güvenli bir yer seçin.
- Makinede sadece orijinal yedek parçalar kullanılmalıdır.

 Kurulumdan önce makinenin fişini çekin.

 Makinenin kurulumu yalnızca yetkili servis personeli tarafından yapılmalıdır. Yetkili servis personelinden başkası tarafından yapılan kurulum, garantinizin geçersiz kalmasına neden olabilir.

 İç mekandaki elektrik sigorta sisteminin güvenlik düzenlemelerine uygun bir şekilde bağlandığından emin olun.

 Bütün elektrik bağlantılarının levhada belirtilen değerlerle aynı olması gerekir.

 Makinenin, elektrik kablosunun üstünde durmadığından emin olun.

 Bağlantı yapmak için asla uzatma kablosu kullanmayınız.

 Makine kurulduktan sonra fiş erişilebilir olmalıdır.

- Kurulum sonrasında makinenizi ilk seferinde yüksüz çalıştırın.

 Kurulum sırasında makine, prize takılı olmamalıdır.

⚠ Her zaman makine ile birlikte verilen kaplamalı fiş kullanın.

⚡⚠ Elektrik kablosu hasarlıysa yalnızca kalifiye bir elektrikçi tarafından değiştirilmelidir.

- Hortumu doğrudan su giriş musluğuna bağlayın. Musluktan gelen basınç minimum 0,03 MPa, maksimum 1 MPa olmalıdır. Basınç 1 MPa değerini aşıyorsa bağlantının arasına bir basınç giderme valfi takılmalıdır.

### 1.3 Kullanım Sırasında

- Makine yalnızca evde kullanıma yöneliktir; makineyi başka amaçlarla kullanmayın. Makinenin ticari amaçlarla kullanılması halinde garanti geçersiz kalır.

⚠ Makinenin açık kapağının üstüne çıkmayın, oturmayın ve yük koymayın.

⚠ Yalnızca özel olarak bulaşık makineleri için üretilen deterjan ve parlaticıları kullanın. Şirketimiz, yanlış kullanımdan kaynaklanan hasarlardan sorumlu değildir.

⚠ Makineden su içmeyin.

⚠ Patlama tehlikesi olması nedeniyle, makinenin yıkama bölümüne kimyasal çözücü maddeler koymayın.

- Plastik ürünleri makinede yıkamadan önce ısı dayanımlarını kontrol edin.

⚠ Makineye yalnızca makinede yıkamaya uygun ürünleri koyun ve sepetleri fazla doldurmamaya özen gösterin.

⚠ Makine çalışırken kapağı açmayın; sıcak su dökülebilir. Kapıyı açmanız halinde emniyet sistemi makinenin durmasını sağlar.

⚠ Makine kapağı açık bırakılmamalıdır. Aksi takdirde, kazalar meydana gelebilir.

⚠ Bıçaklar ve diğer sivri nesnelere çatal-bıçak sepetine sivri uçları aşağı bakacak şekilde yerleştirin.

⚡⚠ Otomatik kapak açma sistemine sahip modellerde Enerji Tasarrufu seçeneği etkinken, kapak program sonunda açılır. Bulaşık makinenizin zarar görmesini önlemek için, kapak açıldıktan sonraki bir dakika boyunca kapağı kapatmaya çalışmayın. Etkin kurutma için, program sona erdikten sonra kapağı 30 dakika boyunca açık tutun. Otomatik açılma sinyalini duyduktan sonra kapağın önünde durmayın.



⚠ Arıza halinde, makine yalnızca yetkili servis şirketi tarafından onarılmalıdır. Aksi takdirde, garanti geçersiz kalır.

⚡⚠ Onarım öncesinde makinenin şebeke bağlantısı kesilmelidir. Makinenin fişini prizden çekerken kablodan tutmayın. Su musluğunu kapatın.

🔇 Düşük voltajda çalıştırmak performansın düşmesine neden olur.

⚠ Güvenlik için, program bittikten sonra fişi çekin.

 Elektrik çarpmasını önlemek için, makinenin fişini ıslak elle çekmeyin.

  Makinenin şebeke bağlantısını keserken fişi tutun; kabloyu kesinlikle çekmeyin.

## 2 KURULUM

### 2.1 Makinenin Konumlandırılması

Makineyi konumlandırırken, bulaşıkları kolayca yerleştirip çıkarabileceğiniz bir yer seçin. Makineyi, ortam sıcaklığının 0°C altına düştüğü bir yere kurmayın.

Ambalajı çıkarmadan ve makineyi yerleştirmeden önce ambalajda yer alan tüm uyarıları okuyun.

Makineyi, musluk ve atık su giderine yakın bir yere yerleştirin. Makine konumlandırıldıktan sonra bağlantıların değiştirilemeyeceğini unutmayın.

Makineyi kapağından veya panelinden tutmayın.

Temizlik yaparken hareket kolaylığı sağlamak için makinenin etrafında yeterli mesafe bırakın.

 Konumlandırma yaparken, su giriş ve çıkış hortumlarının sıkışmadığından ve takılmadığından ve makinenin, elektrik kablosunun üzerinde durmadığından emin olun.

Ayakları, makine düz ve dengeli duracak şekilde ayarlayın. Makine düz bir zemine yerleştirilmelidir. Aksi takdirde, dengesiz durur ve kapağı tam kapanmaz.

### 2.2 Su Bağlantısı

Makinenizin iç tesisattan kaynaklı kirlenme (kum, pas vb.) nedeniyle zarar görmesini önlemek için su girişi beslemesine bir filtre takmanızı öneririz. Bu sayede, yıkama sonrasında sararma ve kalıntı oluşumunu da önlemiş olursunuz.

Su girişi hortumunun üzerinde yazan not! Modeller 25° işaret taşıyorsa, su sıcaklığı maksimum 25 °C (soğuk su) olabilir. Diğer tüm modeller için: Soğuk su tercih edilir, sıcak su maksimum 60°C olmalıdır.

### 2.3 Su Giriş Hortumu





 **UYARI:** Makinenizle birlikte verilen yeni su giriş hortumunu kullanın; eski makinenin hortumunu kullanmayın.

 **UYARI:** Bağlantıyı yapmadan önce yeni hortumdan su akıtın.

 **UYARI:** Hortumu doğrudan su giriş musluğuna bağlayın. Musluktan gelen basınç minimum 0,03 MPa, maksimum 1 MPa olmalıdır. Basınç 1 MPa değerini aşıyorsa bağlantının arasına bir basınç giderme valfi takılmalıdır.

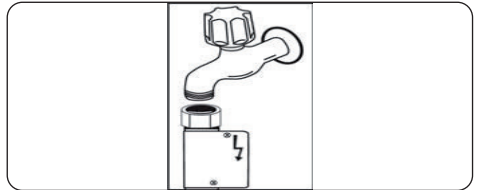
 **UYARI:** Bağlantıları yaptıktan sonra musluğu tamamen açın ve su kaçağı olup olmadığına bakın. Yıkama programı bittikten sonra su giriş musluğunu mutlaka kapatın.



 Bazı modellerde Aquastop su ağızı bulunur. Bu parçaya zarar vermeyin, bükülmesine veya kıvrılmasına izin vermeyin.

## 2.4 Tahliye Hortumu (Modele Bağlı)

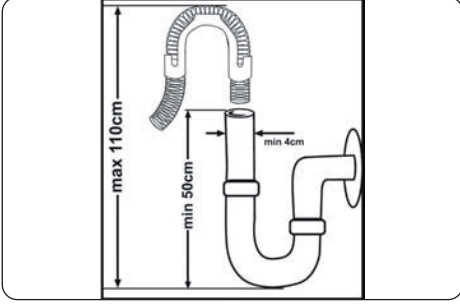

Su tahliye hortumunu doğrudan su tahliye deliğine veya lavabodaki çıkış spigotuna bağlayın. Bu bağlantı, bulaşık makinesinin yerleştirildiği zeminden minimum 50 cm, maksimum 110 cm yükseklikte olmalıdır.



**ÖNEMLİ:** Kullandığınız tahliye hortumu 4 metreden uzunsa bulaşıklar düzgün yıkanmaz.

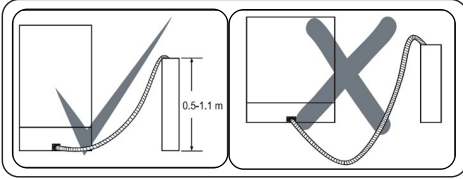

## 2.5 Elektrik Bağlantısı



**UYARI:** Makineniz 220-240 V ile çalışacak şekilde tasarlanmıştır. Makinenize giden şebeke voltajı beslemesi 110 V ise elektrik bağlantısının arasına 110/220 V ve 3000 W değerinde bir transformatör bağlayın.



**Ürünü, “Teknik Özellikler” tablosunda belirtilen değerlere uyan bir sigortanın koruduğu topraklı bir prize bağlayın.**



**Makinenin topraklı fişi, uygun voltaj ve akımla beslenen topraklı bir prize takılmalıdır.**



**Topraklama bağlantısı toksa yetkili bir elektrikçi topraklama bağlantısı yapmalıdır. Makinenin topraklama bağlantısı olmadan kullanılması halinde şirketimiz hiçbir zarardan ve kayıptan sorumlu olmayacaktır.**



**Bu cihazdaki fiş, ilgili ülkeye bağlı olarak 13 A sigorta içerebilir. (Örneğin Birleşik Krallı, Suudi Arabistan)**

### 3 TEKNİK ÖZELLİKLER

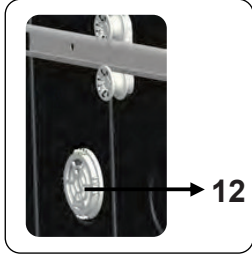
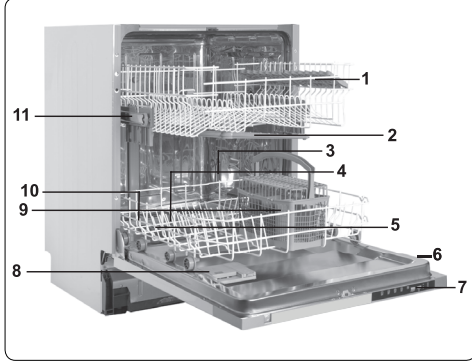

#### 3.1 Genel Görünüm

1. Tezgah
2. Raflı üst sepet
3. Üst püskürtme kolu
4. Alt sepet
5. Alt püskürtme kolu
6. Filtreler
7. Anma değeri plakası
8. Kontrol paneli
9. Deterjan ve yumuşatıcı haznesi
10. Çatal-bıçak sepeti
11. Tuz haznesi
12. Üst sepet tutma mandalı
13. **Mini Aktif Kurutma Ünitesi** Bu sistem bulaşıkların daha iyi kurutulmasını sağlar.

#### 3.2 Teknik Özellikler

Yıkama kapasitesi	12 kişilik standart yemek takımı
Boyutlar Yükseklik Genişlik Derinlik	820-870 (mm) 598 (mm) 570 (mm)
Net weight	31,400 kg
Çalışma gerilimi/ frekansı	220-240V 50 Hz
Toplam akım	10(A)
Toplam güç	1900(W)
Su basıncı	Maksimum 1 (Mpa) Minimum: 0,03 (Mpa)

## GERİ DÖNÜŞÜM

- Makinenin bazı bileşenleri ve ambalaj materyalleri geri dönüştürülebilir malzemeden üretilmiştir.
- Plastik parçalar uluslararası kısaltmalarla işaretlenmiştir: (>PE<, >PP<, etc. )
- Karton parçalar geri dönüştürülmüş kağıttan elde edilmiştir. Bunlar, geri dönüştürülmek üzere atık kağıt kutularına atılabilir.
- Ev tipi atığa uygun olmayan malzemeler geri dönüşüm merkezlerine götürülmelidir.
- Farklı malzemelerin geri dönüşümüyle ilgili bilgi almak için uygun bir geri dönüşüm merkeziyle iletişime geçin.

## AMBALAJ VE ÇEVRE

- Ambalaj malzemeleri, makinenizi taşıma sırasında meydana gelebilecek hasarlara karşı korur. Ambalaj malzemeleri geri dönüştürülebilir olduğu için çevre dostudur. Geri dönüştürülmüş malzeme kullanımı, ham madde tüketimini ve dolayısıyla atık üretimini azaltır.

## CE Uygunluk Beyanı

Ürünlerimizin ilgili Avrupa Direktiflerine, Kararlarına ve Düzenlemelerine, ayrıca atıfta bulunulan standartlarda belirtilen gerekliliklere uygun olduğunu beyan ederiz.

## Eski Makinenin Elden Çıkarılması



Ürün veya ambalajı üzerinde bulunan sembol, bu ürünün ev tipi atık olarak sınıflandırılmayacağını belirtir. Bunun yerine ürün, elektrikli ve elektronik eşyaların geri

dönüştürülmesi için belirlenmiş uygun bir toplama noktasına götürülmelidir. Bu ürünün doğru şekilde elden çıkarılmasını sağlayarak, yanlış elden çıkarmanın çevre ve insan sağlığı üzerinde yaratabileceği

potansiyel olumsuz sonuçların önlenmesini sağlamış olursunuz. Bu ürünün geri dönüştürülmesine ilişkin daha detaylı bilgiler için belediyenizle, ev atık hizmetleriyle veya ürünü satın aldığınız mağazayla görüşebilirsiniz.



## 4 CİHAZI KULLANMADAN ÖNCE

### 4.1 Bulaşık Makinenizi İlk Kullanıma Hazırlama

- Elektrik ve su şebekesi özelliklerinin, makinenin kurulum talimatlarında belirtilen değerlere uygun olduğunu doğrulayın.
- Makinenin içindeki tüm ambalaj malzemelerini çıkarın.
- Su yumuşatıcı seviyesini ayarlayın.
- Parlatici bölmesini doldurun.

### 4.2 Tuz Kullanımı (VARSA)

İyi bir yıkama fonksiyonu için bulaşık makinesinin yumuşak, yani daha az kireçli suya ihtiyacı vardır. Aksi takdirde, bulaşıklarda ve ekipmanın iç kısımlarında beyaz kireç kalıntıları kalacaktır. Bu, makinenizin yıkama, kurutma ve parlatma performansını olumsuz etkileyecektir. Su, yumuşatma sisteminden akarken sertliğe yol açan iyonlar sudan temizlenir ve su, en iyi yıkama sonucu elde etmek için gereken sertliğe ulaşır. Sisteme giren suyun sertlik seviyesine bağlı olarak suyu sertleştiren bu iyonlar, yumuşatma sisteminde hızla birikir. Bu nedenle, yumuşatma sisteminin bir sonraki yıkamada da aynı performansla çalışması için tazelenmesi gerekir. Bu amaçla bulaşık makinesi tuzu kullanılır.

Makine, suyu yumuşatmak için yalnızca özel bulaşık makinesi tuzu ile kullanılabilir. Kolayca çözülen küçük taneli veya toz tipindeki tuzları kullanmayın. Başka tipte tuz kullanılması makinenize zarar verebilir.

### 4.3 Tuz doldurun (VARSA)

Yumuşatıcı tuz eklemek için tuz bölmesi kapağını saat yönünün tersine doğru çevirerek açın. (1) (2) İlk kullanım için bölmeyi 1 kg tuz ve suyla (3) ağzına kadar doldurun. Dolumu kolaylaştırmak için varsa huni (4) kullanabilirsiniz. Kapağı tekrar takın ve kapatın. Her 20-30 çevrimden sonra makinenize dolana kadar tuz ekleyin (yaklaşık 1 kg).

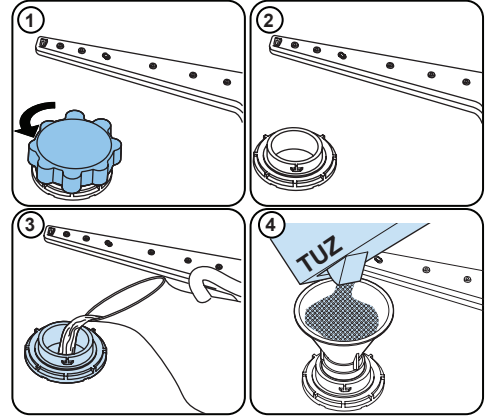



### Tuz bölmesine ilk kullanımda yalnızca su ekleyin.

Özellikle bulaşık makinelerinde kullanım için üretilen yumuşatıcı tuzları kullanın. Bulaşık makinenizi çalıştırdığınızda tuz bölmesi suyla dolu olacaktır. Bu sebeple yumuşatıcı tuzu, makinenizi başlatmadan önce doldurun.

Yumuşatıcı tuz taşıtıysa ve makinenizi hemen çalıştırmayacaksanız makinenizi korozyona karşı korumak için kısa süreli bir yıkama programı başlatın.

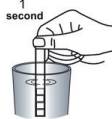
#### 4.4 Test Şeridi

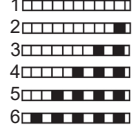
Musluğu açın (1 dk)	Şeridi suya tutun (1 sn)	Şeridi sallayın.	Bekleyin (1 dk)	Makinenizin su sertliği ayarını yapın.
				

**NOT:** Seviye, varsayılan olarak 3'e ayarlıdır. Su, kuyu suyuysa veya 90 dF üzerinde bir sertlik seviyesine sahipse filtre ve arıtım cihazları kullanmanızı tavsiye ederiz.

#### 4.5 Su Sertliği Tablosu

Seviye	Alman sertlik derecesi dH	Fransız sertlik derecesi dF	İngiliz sertlik derecesi dE	Gösterge
1	0-5	0-9	0-6	Ekran L1 görüntülenir.
2	6-11	10-20	7-14	Ekran L2 görüntülenir.
3	12-17	21-30	15-21	Ekran L3 görüntülenir.
4	18-22	31-40	22-28	Ekran L4 görüntülenir.
5	23-34	41-60	29-42	Ekran L5 görüntülenir.
6	35-50	61-90	43-63	Ekran L6 görüntülenir.

#### 4.6 Su Yumuşatıcı Sistem

Bulaşık makinanızda, şebeke suyunun sertliğini azaltan bir su yumuşatıcı yer alır. Musluk suyunuzun sertlik seviyesini öğrenmek için su dağıtım şirketiyle iletişime geçin veya varsa test şeridi kullanın.

#### 4.7 Ayar

- Makinenin kapağını açın.
- Makineyi açın ve ardından Program düğmesine basın.
- "SL" ögesi kaybolana kadar program düğmesini basılı tutun.
- Makine, son ayarı görüntüleyecektir.
- Program düğmesini kullanarak seviyeyi ayarlayın.
- Ayarı kaydetmek için makineyi kapatın.

## 4.8 Deterjan Kullanımı

Yalnızca ev tipi bulaşık makinelerine özel olarak üretilmiş deterjanlar kullanın. Deterjanınızı çocukların erişemeyeceği kuru ve serin bir yerde muhafaza edin.

En iyi performans elde etmek için seçilen programa uygun deterjanı ekleyin. İhtiyaç duyulan deterjan miktarı programa, yük miktarına ve bulaşıkların kir seviyesine bağlıdır.

Deterjan bölmesine gerekenden fazla deterjan doldurmayın; aksi takdirde, cam eşyalar ve bulaşıklar üzerinde beyazımsı çizgiler veya mavimsi katmanlar görülebilir. Sürekli çok fazla deterjan kullanılması makineden hasara neden olabilir.

Çok az deterjan kullanılması yetersiz temizliğe yol açabilir ve suyun sert olduğu hallerde beyazımsı çizgiler görülebilir. Daha fazla bilgi için deterjan üreticisinin talimatlarına bakın.

## 4.9 Deterjan Dolumu

Hazneyi açmak ve deterjanı doldurmak için mandalı itin.

Kapağı kapatın ve yerine oturana kadar üzerine bastırın. Hazne, programa başlamadan önce yeniden doldurulmalıdır. Bulaşıklar çok kirliyse ön yıkama deterjan haznesine deterjan ekleyin.

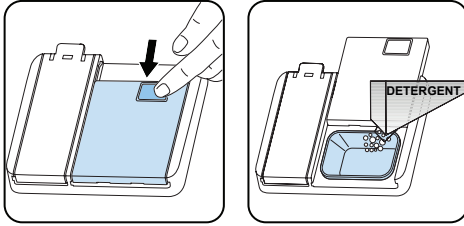

## 4.10 Hepsı Bir Arada Deterjanlar

Üreticinin talimatları gereğince bu ürünler kullanılmamalıdır.

Hepsı bir arada deterjanları kesinlikle iç bölüme veya çatal bıçak sepetine koymayın. Hepsı bir arada deterjanlar, deterjanın yanı sıra karışıma bağlı olarak parlaticı, tuza alternatif maddeler ve ek bileşenler içerebilir.

Kısa programlarda hepsi bir arada deterjanları kullanmanızı önermiyoruz. Bu tür programlarda lütfen toz deterjan

kullanın.

Hepsı bir arada deterjan kullanırken sorun yaşarsanız lütfen deterjan üreticisiyle iletişime geçin.

Hepsı bir arada deterjan kullanmayı bırakırsanız su sertliği ve parlaticı ayarının doğru seviyeye getirildiğinden emin olun.

## 4.11 Parlaticı Kullanımı

Parlaticı, bulaşıkların çizgi ve leke kalmadan kurutulmasına yardımcı olur. Mutfak malzemelerinde leke kalmaması ve camların temizlenmesi için parlaticı kullanılmalıdır. Parlaticı, sıcak durulama aşamasında otomatik olarak salınır. Parlaticı dozaj ayarı çok düşükse, bulaşıklarda beyaz lekeler kalır, bulaşıklar kurumaz ve iyi yıkanmaz.

Parlaticı dozajı ayarı çok yükseğe ayarlanırsa, cam eşyaların ve tabakların üzerinde mavimsi katmanlar görülebilir.

## 4.12 Parlaticı Dolumu ve Ayarı

Parlaticı bölmesini doldurmak için bölmenin kapağını açın. Bölmeye MAX seviyesine kadar parlaticı doldurup kapağı kapatın. Parlaticı bölmesini çok doldurmamaya dikkat edin, dökülen parlaticıyı silin.

### Parlaticı seviyesini değiştirmek için makineyi açmadan önce aşağıdaki adımları izleyin:

- Makinenin kapağını açın.
- Makineyi açın ve ardından Program düğmesine basın.
- "rA" ögesi kaybolana kadar program düğmesini basılı tutun. Parlaticı ayarı, su sertliği ayarını takiben yapılır.
- Makine, son ayarı görüntüleyecektir.
- Program düğmesini kullanarak seviyeyi değiştirin.
- Ayarı kaydetmek için makineyi kapatın. Fabrikada yapılmış ayar "4"tür. Bulaşıklar gerektiği gibi kurumuyorsa veya

lekeliyse seviyeyi yükseltin. Bulaşıklarınızda mavi lekeler varsa seviyeyi düşürün.

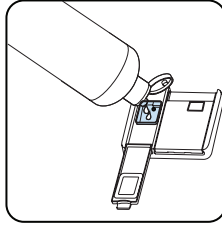
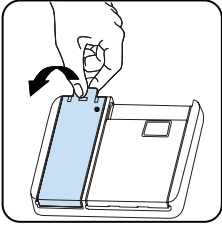

Seviye	Parlatıcı Dozu	Gösterge
1	Parlatıcı kullanılmamış	Ekranda r1 görüntülenir.
2	1 doz kullanılır	Ekranda r2 görüntülenir.
3	2 doz kullanılır	Ekranda r3 görüntülenir.
4	3 doz kullanılır	Ekranda r4 görüntülenir.
5	4 doz kullanılır	Ekranda r5 görüntülenir.

## 5 BULAŞIK MAKİNESİNİN YÜKLENMESİ

En iyi sonuçlar için bu yükleme yönergelerini takip edin.

Ev tipi bulaşık makinesinin üretici tarafından belirtilen kapasiteye kadar yüklenmesi, enerji ve su tasarrufuna katkı sağlayacaktır.

Masa takımlarının manuel olarak önceden sudan geçirilmesi su ve enerji tüketiminin artmasına yol açar ve bu nedenle önerilmemektedir. Fincanları, bardakları, saplı kristal bardakları, kaseleri vb. üst sepete yerleştirebilirsiniz. Uzun bardakları birbirine yaslamayın, aksi takdirde sabit durmazlar ve zarar görebilirler.

Uzun saplı bardakları ve kadehleri yerleştirirken birbirlerine değil sepetin kenarına veya rafa yaslayın.

Fincanlar, bardaklar ve tencereler gibi tüm kapları bulaşık makinesine, açık ağızları aşağı bakacak şekilde yerleştirin; aksi takdirde içlerinde su birikir.

Makinede çatal bıçak sepeti varsa, en iyi sonucu elde etmek için çatal bıçak izgarasını kullanmanız önerilir. Tüm büyük ve çok kirli öğeleri (tencereler, tavalalar, kapaklar, tabaklar, kaseler, vb.) alt rafa yerleştirin.

Bulaşıklar ve çatal bıçaklar birbirinin üzerine yerleştirilmemelidir.



**UYARI:** Püskürtme kollarının dönüşünü engellemeye özen gösterin.



**UYARI:** Bulaşıkları yükledikten sonra deterjan bölmesinin açılmasını engellemeyin.

### 5.1 Öneriler

Bulaşıkları makineye yerleştirmeden önce üzerlerindeki kaba kalıntıları sıyırın.

Makineyi tam yükte çalıştırın.



Çekmeceleri aşırı yüklemeyin veya bulaşıkları yanlış sepete yerleştirmeyin.



**UYARI:** Olası yaralanmaları önlemek için, uzun saplı ve sivri uçlu bıçakları sepete sivri uçları aşağı bakacak ya da yatay şekilde yerleştirin.

### Doluyken Üst Sepet Yükseklik Ayarı

Üst sepet sepetin yüksekliğinin ayarlanmasını sağlayan bir mekanizma içerir.

Üst (1), alt (2) olarak ayarlanabilir veya orta (3) konumda sepeti çıkarmaya gerek kalmadan. Sepeti her iki yanından kavrayın ve üst sepetin her iki tarafının aynı konumda olmasını sağlayarak yukarı veya aşağı doğru çekin.

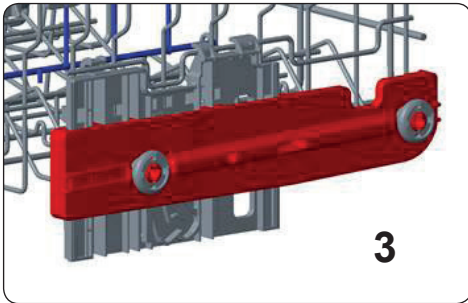
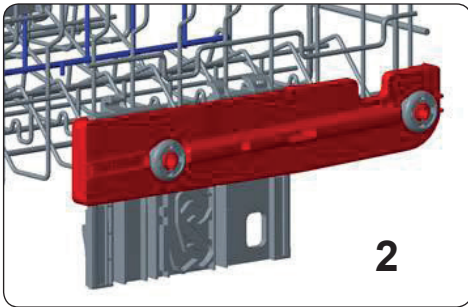
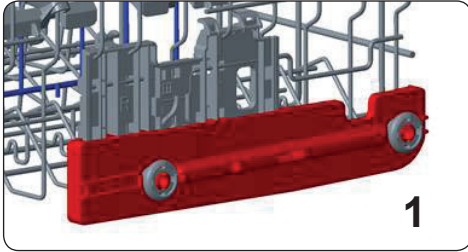

### Yükseklği Ayarlanabilir Raf (mandal tipi)

Üst sepette yer alan katlanır raflar, tencere ve tava gibi büyük gereçleri makineye yerleştirmenizi sağlar. Her bölüm ayrıca katlanabilir. Katlanır raflar yukarı kaldırılabilir veya aşağı doğru katlanabilir.

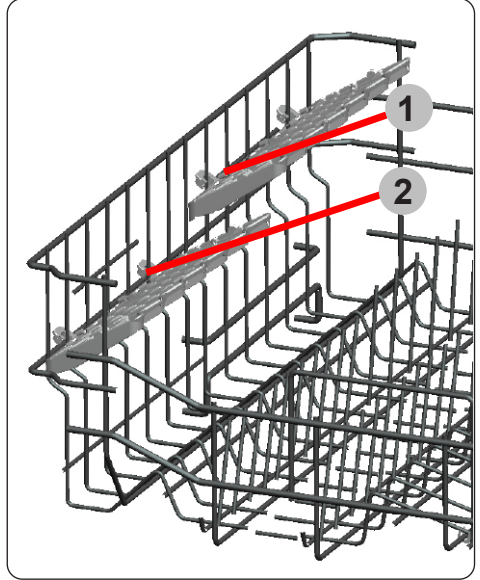

## 5.2 Alternatif Sepet Yükları

### Alt Sepet

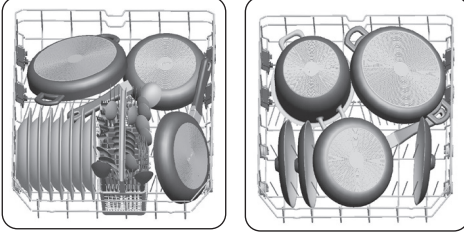

### Üst Sepet

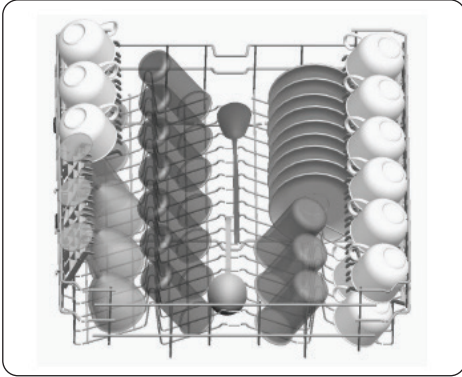

### Yanlış Yükler

Yanlış yükleme, zayıf yıkama ve kurutma performansına yol açabilir. Daha iyi bir performans sonucu için lütfen üreticinin önerilerini izleyin.

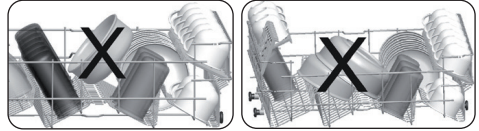
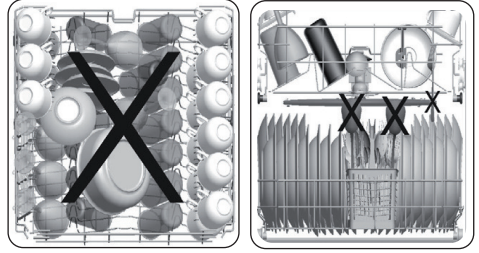

### Bulaşık Makinesinde Yıkamaya Uygun Olmayan Şeyler

- Sigara külü, mum artığı, cila, petrol, boya, kimyasal madde bulunan bulaşıklar ve çelik demir alaşımli materyaller.
- Tahta ya da kemik saplı fildişi, sedef kaplama, çatal, kasık, bıçaklar, yapıştırılmış parçalar ve aşındırıcı, asitli ya da alkali kimyasallar ile kirlenmiş parçalar.
- Sıcaklık hassasiyeti olan plastikler, bakır veya teneke kaplı parçalar.
- Alüminyum ve gümüş nesnelere.
- Hassas cam gereçler, süs amaçlı baskılı porselenler, bazı kristal gereçler, yapışkanlı çatal-bıçaklar, kurşun kristal bardaklar, kesme tahtaları, sentetik fiber gereçler.
- Sünger veya mutfak halıları.



**ÖNEMLİ:** Bundan sonrası için, bulaşık makinesinde yıkamaya uygun mutfak gereçleri satın alın.

### Test Laboratuvarları İçin Önemli Not

EN normları uyarınca yapılan testler için gereken detaylı bilgiler ve kılavuzun elektronik kopyası için lütfen model adını ve seri numarasını şu adrese gönderin: [dishwasher@standardtest.info](mailto:dishwasher@standardtest.info)

## 6 PROGRAM TABLOSU

	P1	P2	P3	P4	P5	P6
Program Adı	Eko 50°C	Yoğun 70°C	Hygiene 70°C	Süper 50 dk. 65°C	Hızlı 30dk. 40°C	Ön Yıkama
Kir Türü:	Normal düzeyde kirli günlük bulaşıkları daha az elektrik ve su kullanarak yıkamaya uygun program.	Çok kirli bulaşıklar için.	Suitable for heavily soiled dishes requiring hygienic washing.	Normal düzeyde kirli, günlük kullanılan bulaşıklar için daha hızlı program.	Hafif kirli bulaşıklar ve hızlı yıkama için uygundur.	Daha sonra yıkayacağımız bulaşıkları durulamak için uygundur.
Kir Seviyesi:	Orta	Yoğun	Heavy	Orta	Hafif	Hafif
"Deterjan Miktarı: A: 25 cm3 B: 15 cm3"	A	A	A	A	A	-
Program Süresi (sa:dk):	03:25	01:57	02:07	00:50	00:30	00:15
Elektrik tüketimi (kW/çevrim):	0.923	1.700	1.900	1.100	0.740	0.020
Su tüketimi (litre/çevrim):	12.0	17.2	16.0	12.0	12.4	4.5

- Program süresi bulaşık miktarına, su sıcaklığına, ortam sıcaklığına ve seçilen ek fonksiyonlara göre değişebilir.
- Eco programı dışındaki programlar için verilen değerler yalnızca bilgi niteliğindedir
- Eco programı, normal kirli sofrta takımlarını temizlemek için enerji ve su tüketimi kombinasyonu açısından en verimli programdır ve AB eko tasarım mevzuatına uygunluğu değerlendirilmek için kullanılır.
- Bulaşık makinesi, üreticinin talimatlarına uygun olarak kullanıldığında genellikle elde bulaşık yıkamaya göre daha az enerji ve su tüketir.
- Kısa programlar için yalnızca toz deterjan kullanın.
- Kısa programlar kurutma adımı içermez.
- Kurutmaya yardımcı olmak için, bir döngü tamamlandıktan sonra kapağı bir miktar açmanızı öneririz.
- Model bilgilerinin depolandığı ürün veri tabanına enerji etiketindeki QR kodunu okutarak erişebilirsiniz.



NOT: 1016/2010 ve 1059/2010 yönetmeliklerine göre, Eco programı enerji tüketimi değerleri farklılık gösterebilir. Bu tablo 2019/2022 ve 2017/2022 düzenlemelerine uygundur.



## 7. KONTROL PANELİ

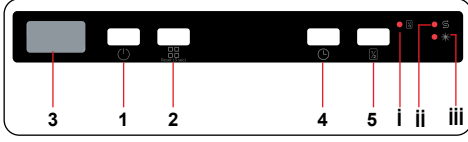

1. Açma/Kapama Düğmesi
2. Program Seçim Düğmesi
3. Ekran
4. Erteleme Düğmesi
5. Yarım Yük Düğmesi
  - i. Yarım Yük LED'i
  - ii. Tuz Göstergesi
  - iii. Parlatıcı Göstergesi

### 1. Açma/Kapama Düğmesi

Açma/Kapama düğmesine basarak makineyi açın. Makine açıldığında Ekranda (3) "--" gösterilecektir.

### 2. Program Seçim Düğmesi

Program Seçim düğmesine basarak bulaşıklarınız için uygun bir program seçin. Kapak kapatıldığında program otomatik olarak başlar.

### 3. Ekran

Ekranda seçilen programın numarası ve süresi ve ayrıca çalışma sırasında kalan süre sırayla gösterilir.

### 4. Erteleme Düğmesi

Erteleme düğmesine basarak, seçtiğiniz programın başlangıç saatini 1 ila 19 saat erteleyebilirsiniz. Düğmeye bir kez bastığınızda başlangıç zamanı 1 saat ertelenir. Basmaya devam ettikçe erteleme süresi de artar. Ertelemeli başlatmayı değiştirmek veya iptal etmek için Erteleme düğmesine basın. Erteleme zamanlayıcısı etkinken makineyi kapatırsanız erteleme zamanı iptal edilir.

### 5. Yarım Yük Düğmesi

Seçtiğiniz programın süresini kısaltarak enerji ve su tüketimini azaltmak için Yarım Yük düğmesine basın. Yarım Yük seçeneği seçildiğinde Yarım Yük LED'i (i) yanacaktır.

**NOT:** Seçtiğiniz programı başlatmak istemezseniz lütfen "Program Değiştirme" ve "Programın İptal Edilmesi" bölümlerini okuyun.

**NOT:** Yeteri kadar yumuşatıcı tuz yoksa tuz haznesini doldurulması gerektiğini belirtmek için Yetersiz Tuz Uyarı Göstergesi (ii) ışığı yanacaktır.

**NOT:** Yeteri kadar parlatıcı olmadığında parlatıcı haznesinin doldurulması gerektiğini belirtmek için Yetersiz Parlatıcı Uyarı Göstergesi (iii) ışığı yanacaktır.

### 7.1. Program Değiştirme

Makinenin çalışması sırasında programı değiştirmek için aşağıdaki adımları izleyin.

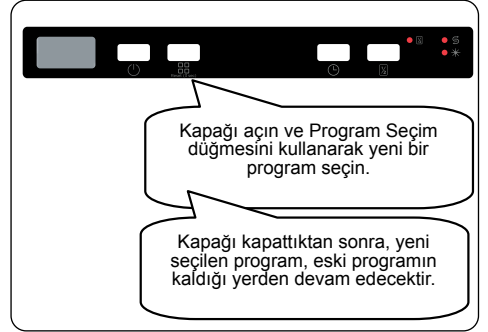

**NOTE:** Yıkama programını bitmeden durdurmak istiyorsanız suyun dökülmesini engellemek için makinenin kapağını hafif açın.

## 7.2. Programın İptal Edilmesi

Makinenin çalışması sırasında programı iptal etmek için aşağıdaki adımları izleyin.

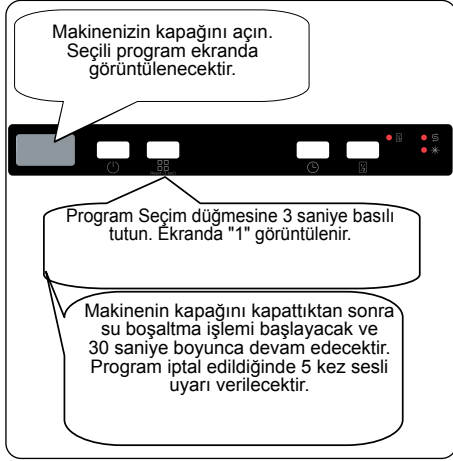

## 7.3. Makinenin Kapatılması

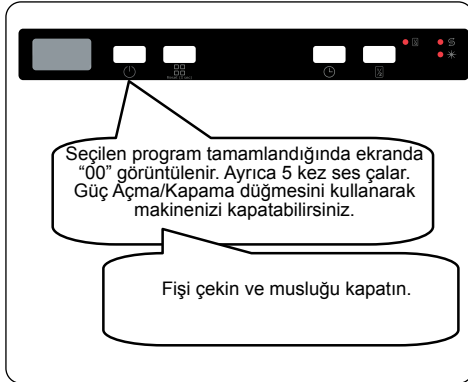

**NOT:** Kapağı, program bitmeden önce açmayın.

**NOT:** Program devam ederken makinenin kapağı açılırsa veya elektrik kesilirse, kapak kapatıldığında veya elektrik geldiğinde program kaldığı yerden devam eder.

**NOT:** Kurutma işlemi sırasında elektrik kesilirse veya makinenin kapağı açılırsa program sona erer. Makineniz, yeni bir program seçimi için hazır hale gelir.

## Uyarı Sesi Kontrolü

Uyarı sesi seviyesini değiştirmek için aşağıdaki adımları izleyin:

1. Kapağı açıp Program (2) ve Erteleme (4) düğmelerine aynı anda 3 saniye basın.
2. Ses uyarı algılandığında, uzun bir uyarı sesi verilir ve makine "S0" ile "S3" arasında olmak üzere son ayarlanan seviyeyi gösterecektir.
3. Ses seviyesini azaltmak için Program düğmesine (2) basın. Ses seviyesini artırmak için Erteleme düğmesine (4) basın.
4. Seçilen ses seviyesini kaydetmek için makineyi kapatın.

"S0" seviyesi tüm seslerin kapalı olduğu anlamına gelir. Fabrikada "S3" olarak ayarlanmıştır.

## Güç Tasarrufu Modu

Güç tasarrufu modunu etkinleştirmek veya devre dışı bırakmak için aşağıdaki adımları izleyin:

1. Kapağı açıp Erteleme (4) ve Yarım Yük (5) düğmelerine aynı anda 3 saniye basın.
2. 3 saniye sonra makine son ayar olan "IL1" veya "IL0" ayarını görüntüleyecektir.
3. Güç Tasarrufu Modu etkinleştirildiğinde "IL1" görüntülenecektir. Bu modda, enerji tasarrufu yapmak için iç lambalar kapı açıldıktan 4 dakika sonra sönecek ve makine 15 dakika hiçbir işlem yapılmazsa kapanacaktır.
4. Güç Tasarrufu Modu devre dışı bırakıldığında "IL0" görüntülenecektir. Güç Tasarrufu Modu devre dışı bırakılırsa iç ışıklar kapı açık olduğu sürece yanacak ve makine, kullanıcı tarafından kapatılmadığı sürece açık kalacaktır.
5. Seçilen uyarı kaydetmek için makineyi kapatın.

Fabrika ayarlarında Güç Tasarrufu Modu etkindir.

## Infoled 2.1 (Modele Bağlıdır)

LED Gösterge	Makine Durumu
Kırmızı, sürekli	Makine bir program çalıştırıyor.
Kırmızı, yanıp sönüyor	Bir program iptal edilmiştir
Kırmızı, hızlı yanıp sönüyor	Makinede bir arıza vardır. <b>Otomatik arıza uyarıları ve yapılması gerekenler</b> bölümüne bakın.
Yeşil, sürekli	Bir program bitmiştir.

## 8 TEMİZLİK VE BAKIM

Bulaşık makinenizi temizlemek, makinenin hizmet ömrü açısından çok önemlidir. Kireç birikmesini engellemek için su yumuşatma ayarının (varsa) doğru yapıldığından ve doğru miktarda deterjan kullandığınızdan emin olun. Tuz sensörü ışığı yandığında tuz bölümünü doldurun. Zamanla bulaşık makinenizde yağ ve kireç birikebilir. Bu meydana gelir:

- Deterjan bölmesini doldurun ama bulaşık koymayın. Yüksek sıcaklıkta çalışan bir program seçin ve bulaşık makinesini boş çalıştırın. Bu işlem bulaşık makinenizi yeterince temizlemeze, bulaşık makinelerinde kullanılmak üzere tasarlanmış bir temizlik maddesi kullanın.
- Bulaşık makinenizin ömrünü uzatmak için cihazı her ay olmak üzere düzenli aralıklarla temizleyin.
- Birikmiş tortuları veya yabancı nesnelere temizlemek için kapı contalarını nemli bir bezle düzenli aralıklarla silin.

### 8.1 Filtreler

Filtreleri ve püskürtme kollarını en az haftada bir temizleyin. Kalın ve ince filtrelerde herhangi bir yiyecek artığı veya yabancı nesne kalırsa bunları sıyırın ve suyla iyice temizleyin.

- a) Mikro Filtre b) Kalın Filtre  
c) Metal Filtre

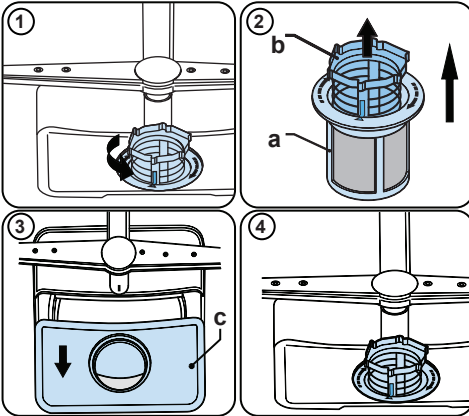

Filtre kombinasyonunu çıkarmak ve temizlemek için saatin aksi yönde çevirip yukarı kaldırmak suretiyle çıkarın (1). Kalın fitreyi çekerek mikro filtreden çıkarın (2). Ardından metal filtreyi çekip çıkarın (3). Filtreyi, kalıntılardan temizlenene kadar bol suyla durulayın. Filtreleri tekrar birleştirin. Filtre grubunu yerine takın ve saat yönünde (4) çevirin.

- Bulaşık makinesini asla filtresiz kullanmayın.
- Filtrenin hatalı takılması yıkama verimini azaltacaktır.
- Makinenin uygun şekilde çalışması için filtrelerin temiz olması gerekir.

### 8.2 Püskürtme Kolları

Püskürtme deliklerinin tıkalı olmadığından ve püskürtme kollarına yemek artıkları veya yabancı nesnelere sıkışmadığından emin olun. Tıkanıklık varsa, püskürtme kollarını çıkarın ve su altında temizleyin. Üst püskürtme kolunu çıkarmak için kolu sabit tutup somunu saatin aksi yönde çevirin ve kolu aşağı çekerek çıkarın. Üst püskürtme kolunu geri takarken somunun uygun şekilde sıkıldığından emin olun.

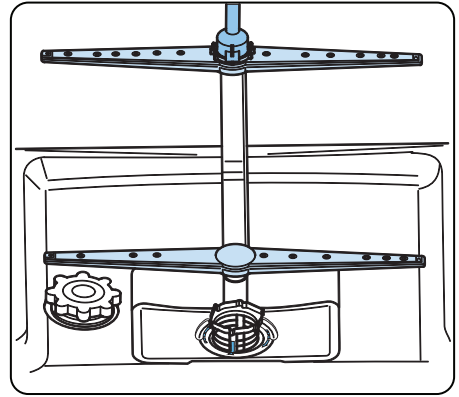

### 8.3 Tahliye Pompası

Filtrelerin yakalayamadığı büyük yemek kalıntıları ve yabancı nesnelere, atık su pompasını tıkayabilir. Bu durumda durulama suyu seviyesi filtrenin üzerinde olacaktır.

**⚠ Uyarı! Kesik riski!**

Atık su pompasını temizlerken kırık cam parçaları veya sivri uçlu eşyalar nedeniyle kendinizi yaralamadığınızdan emin olun.

Bu durumda:

1. Öncelikle cihazın güç kaynağını her zaman kesin.
2. Sepetleri çıkartın.
3. Filtreleri çıkartın.
4. Suyu dışarı atın, gerekirse bir sünger kullanın.
5. İlgili alanı kontrol edin ve tüm yabancı nesnelere temizleyin.
6. Filtreleri takın.
7. Sepetleri geri takın.

## 9 SORUN GİDERME

ARIZA	OLASI NEDEN	SORUN GİDERME
Program başlamıyor.	Bulaşık makinenizin fişi prize takılı değildir.	Bulaşık makinenizin fişini prize takın.
	Bulaşık makineniz açık değildir.	Açma/Kapama düğmesine basarak makineyi açın.
	Sigorta atmıştır.	Evinizin içindeki sigortaları kontrol edin.
	Su giriş musluğu kapalıdır.	Su giriş musluğunu açın.
	Bulaşık makinenizin kapağı açıktır.	Bulaşık makinenizin kapağını kapatın.
	Su giriş hortumu ve makine filtreleri tıkalıdır.	Su giriş hortumlarını ve makine filtrelerini kontrol ederek tıkalı olmadıklarından emin olun.
Makinenin içinde su kalıyor.	Su tahliye hortumu tıkanmıştır veya bükülmüştür.	Tahliye hortumunu kontrol edin ve temizleyin ya da düzeltin.
	Filtreler tıkanmıştır.	Filtreleri temizleyin.
	Program henüz bitmemiştir.	Program bitene kadar bekleyin.
Yıkama sırasında makine duruyor.	Elektrik kesintisi olabilir.	Şebeke elektriğini kontrol edin.
	Su giriş arızası olabilir.	Su musluğunu kontrol edin.
Yıkama işlemi sırasında sallanma ve vurma sesleri duyuluyor.	Püskürtme kolu, alt sepetteki bulaşıklara çarpıyor.	Püskürtme kolunu engelleyen bulaşıkları başka yer koyun veya çıkarın.
Bulaşıklarda yer yer yemek artığı kalıyor.	Bulaşıkların yanlış yerleştirilmesi nedeniyle, püskürtülen su bulaşıklara erişmiyordur.	Sepetleri kapasitesinden fazla dolurmayın.
	Bulaşıklar birbirinin üstüne gelecek şekilde yerleştiriliyordur.	Bulaşıkları, Bulaşık Makinenizin Yüklenmesi bölümünde belirtildiği şekilde yerleştirin.
	Yeterli deterjan kullanılmıyordur.	Program tablosunda belirtildiği şekilde, yeterli miktarda deterjan kullanın.
	Yanlış yıkama programı seçilmiştir.	Program tablosundaki bilgileri kullanarak en uygun programı seçin.
	Yiyecek artıkları püskürtme kollarını tıkanmıştır.	Püskürtme kollarındaki delikleri ince bir nesneyle temizleyin.
	Filtreler veya su tahliye pompası tıkanmıştır ya da filtre yanlış takılmıştır.	Tahliye hortumunun ve filtrelerin doğru şekilde takıldığından emin olun.

ARIZA	OLASI NEDEN	SORUN GİDERME
Bulaşıklarda beyazımsı lekeler kalıyor.	Yeterli deterjan kullanılmıyordur.	Program tablosunda belirtildiği şekilde, yeterli miktarda deterjan kullanın.
	Parlatıcı dozu ve/veya su yumuşatma ayarı çok düşüktür.	Parlatıcı miktarını artırın ve/veya su yumuşatma seviyesini yükseltin.
	Su sertliği seviyesi yüksektir.	Su sertliği seviyesini yükseltin ve tuz ekleyin.
	Tuz bölmesinin kapağı iyi kapatılmamıştır.	Tuz bölmesinin kapağının iyi kapatıldığından emin olun.
Bulaşıklar kurumuyor.	Kurutma seçeneği seçilmemiştir.	Kurutma seçeneği olan bir program seçin.
	Parlatıcı dozajı çok düşük bir seviyeye ayarlanmıştır.	Parlatıcı dozajı ayarını artırın.
Bulaşıklarda pas lekeleri oluşuyor.	Bulaşıkların paslanmaz çelik kalitesi yetersizdir.	Yalnızca bulaşık makinesinde yıkamaya uygun ürünler kullanın.
	Yıkama suyundaki tuz oranı yüksektir.	Su sertliği tablosundan faydalanarak su sertliği seviyesini ayarlayın.
	Tuz bölmesinin kapağı iyi kapatılmamıştır.	Tuz bölmesinin kapağının iyi kapatıldığından emin olun.
	Tuz dolumu yaparken bulaşık makinesine çok fazla tuz döküldü.	Dökülmeyi önlemek için bölmeye tuz doldururken huni kullanın.
	Şebeke topraklaması zayıftır.	Derhal kalifiye bir elektrikçiyle iletişime geçin.
Deterjan bölümünde deterjan kalıyor.	Deterjan bölümü ıslakken bölmeye deterjan eklenmiştir.	Kullanım öncesinde deterjan bölümünün kuru olduğundan emin olun.

## OTOMATİK ARIZA UYARILARI VE YAPILMASI GEREKENLER

ARIZA KODU	OLASI ARIZA	ÇÖZÜM
FF	Su giriş sistemi arızası	Su giriş musluğunun açık olduğundan ve suyun aktığından emin olun.
		Giriş hortumunu musluktan ayırıp hortumun filtresini temizleyin.
		Arıza devam ederse servisle iletişime geçin.
F5	Basınç sistemi arızası	Servisle iletişime geçin.
F3	Sürekli su girişi	Musluğu kapatıp servisle iletişime geçin.
F2	Su tahliye edilmiyor	Su tahliye hortumu ve filtreler tıkanmış olabilir.
		Programı iptal edin.
		Arıza devam ederse servisle iletişime geçin.
F8	Isıtıcı hatası	Servisle iletişime geçin.
F1	Taşma	Makinenizi ve musluğu kapatın.
		Servisle iletişime geçin.
FE	Arızalı elektronik kart	Servisle iletişime geçin.
F7	Aşırı ısınma	Servisle iletişime geçin.
F6	Hatalı ısıtma sensörü	Servisle iletişime geçin.
HI	Yüksek voltaj arızası	Servisle iletişime geçin.
LO	Düşük voltaj arızası	Servisle iletişime geçin.

Olası riskleri önlemek için kurulum ve onarım prosedürleri her zaman Yetkili Servis tarafından gerçekleştirilmelidir. Üretici, yetkili olmayan kişiler tarafından gerçekleştirilen prosedürlerden kaynaklanabilecek hasarlardan dolayı sorumlu tutulamaz. Onarımlar yalnızca teknisyenler tarafından gerçekleştirilebilir. Bir bileşenin değiştirilmesi gerekiyorsa, yalnızca orijinal yedek parçaların kullanıldığından emin olun.

Uygun olmayan onarım işlemleri veya orijinal olmayan yedek parçaların kullanılması ciddi hasara neden olabilir ve kullanıcıyı ciddi risklerle karşı karşıya bırakabilir.

Müşteri hizmetinizi için iletişim bilgileri bu belgenin arka kısmında bulunmaktadır.

İlgili Ecodesign siparişine göre fonksiyonla ilgili orijinal parçalar, cihazınızın Avrupa Ekonomik Alanı dahilinde piyasaya sürülmüş olduğu tarihten itibaren 10 yıl süreyle Müşteri Hizmetleri biriminden temin edilebilir.

**CE**



**XXXXX**

